

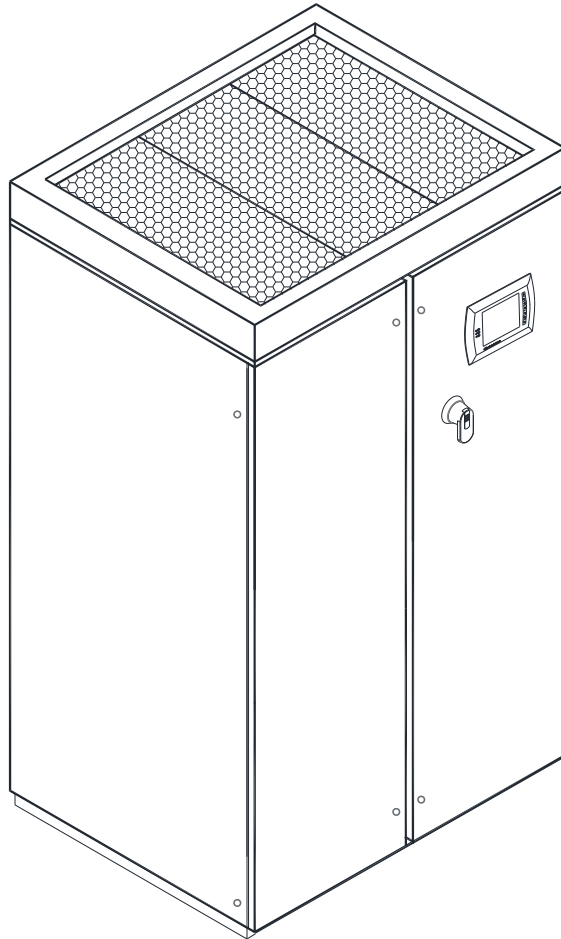

**SYSTEM 2100**  
**AIR COOLED CAA-6 TO 12 TON KOMPACT**  
**-INSTALLATION OPERATIONS AND MAINTENANCE MANUAL**



**8167 Byron Road Whittier, CA 90606**  
**Phone: (562) 945-8971 Fax: (562) 696-0724**  
[www.compu-aire.com](http://www.compu-aire.com)

Table of Contents

1.0 CONTACTING COMPU-AIRE FOR TECHNICAL ASSISTANCE ..... 4

2.0 PRODUCT MODEL INFORMATION..... 5

3.0 GENERAL EQUIPMENT DESCRIPTION..... 7

4.0 RECEIPT OF UNIT AND TRANSPORTATION..... 7

5.0 LOCATING THE UNIT ..... 8

6.0 UNIT DIMENSIONS ..... 10

    6.1 Front Layout..... 11

    6.2 Sensors..... 13

    6.3 Low Voltage Control Panel..... 13

    6.4 Refrigeration Components..... 14

    6.5 Unit Left Access..... 15

7.0 REMOTE ALARMS..... 16

8.0 INSTALLATION ..... 17

    8.1 Room Preparation..... 17

    8.2 Location Considerations..... 17

    8.3 Piping..... 18

    8.4 Drain Connection ..... 18

    8.5 Refrigeration Piping ..... 19

    8.6 EVACUATION PROCEDURES ..... 20

    8.7 Charging Procedure ..... 21

    8.8 Liquid Charge ..... 22

    8.9 Vapor Charge ..... 22

    8.10 Leak Testing ..... 23

    8.11 How to Save the Refrigerant Charge..... 23

    8.12 Electrical Connection ..... 24

9.0 STARTUP AND TEST PROCEDURE..... 25

10.0 GENERAL MAINTENANCE..... 27

11.0 TROUBLESHOOTING GUIDE ..... 28

12.0 REFERENCE DOCUMENTS ..... 38

## Table of Figures

Figure 1: LOADING UNITS ..... 8  
Figure 2: SYSTEM OVERVIEW ..... 10  
Figure 3: FRONT VIEW LAYOUT ..... 11  
Figure 4: HIGH VOLTAGE CONTROL PANEL LAYOUT ..... 12  
Figure 5: LOW VOLTAGE CONTROL PANEL LAYOUT ..... 13  
Figure 6 UNIT RIGHT ACCESS ..... 15  
Figure 7: TERMINAL BLOCK W/ SYSTEM CUT-OUT ..... 16  
Figure 8: P-TRAP SCHEMATIC ..... 18  
Figure 9: DRAIN CONNECTION ..... 19  
Figure 10: AIR PRESSURE DIFFERENTIAL SWITCH ..... 27  
Figure 11: TYPICAL SCHEMATIC ..... 40

---

## **1.0 CONTACTING COMPU-AIRE FOR TECHNICAL ASSISTANCE**

---

Compu-Aire, Inc. uses the latest in electronic and software technologies to develop some of the most reliable and cost efficient air conditioning systems in the world. Since many of our customer installations are sensitive to down time, we stock nearly all components for your system ready for same day shipment. In addition, our service departments can usually diagnose and repair the electronic components and return them to you within a few days.

Our customer support staff is available should you require assistance in diagnosing a problem or in setting up your air conditioning system. During usual business hour, you may call at (562) 945-8971 between 8:00am and 5:00pm Pacific time, Monday through Friday except holidays, or you may send a facsimile message at (562) 696-0724 anytime. Finally, you may write us at Compu-Aire, Inc., 8167 Byron Road, Whittier, CA 90606.

Please do not return system components without prior authorization from Compu-Aire. Whether repair or replacement is required for in warranty or out of warranty parts, Compu-Aire must know what is being returned to keep proper records of returned parts. Call Compu-Aire's service center for a returned materials authorization number (RMA) and clearly mark all packages on the outside with the number before sending them to us.

When contacting the factory, please have information ready as to the model and size of the air conditioner system and most important, the job number. Compu-Aire keeps a file on each machine sold detailing system components using this latter number. All such information can be found on the Warranty Plate attached to each machine.

---

## 2.0 PRODUCT MODEL INFORMATION

---

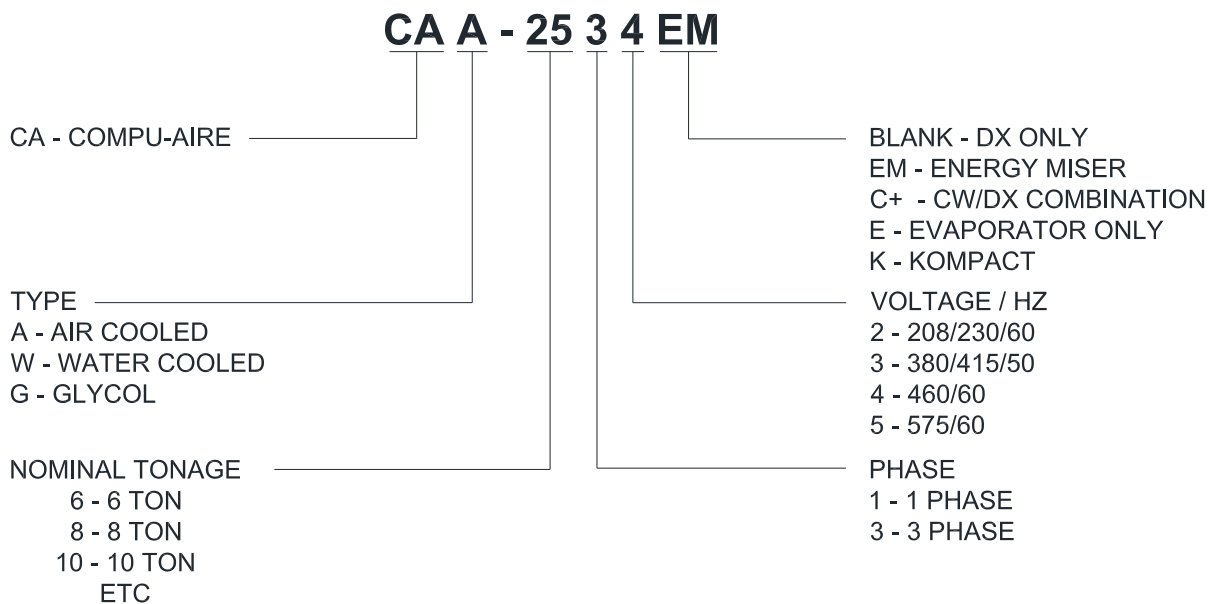

### SAFETY INSTRUCTIONS

This user's manual contains important safety instructions that should be followed to properly install and maintain Compu-Aire system 2100 Kompact series. Read this manual thoroughly before attempting to install or operate this unit. Store this manual at safe place for future reference.

Adhere to all warnings, cautions and safety instructions on the unit and in this manual. Follow all local codes and safety requirements to install and service this unit.



#### WARNING

Installation and service of this equipment should be done by qualified personnel who have been specially trained and qualified in the installation of specific HVAC equipment. Improper installation could result in unaccountable loss or damage. ***COMPU-AIRE System 2100 series equipment requires a permanent power connection from an isolated circuit breaker. Customer must provide earth ground to the unit per NEC, CEC and local codes as applicable.***

- Risk of high speed moving parts can cause injury or death.

- Risk of heavy unit falling over
- Risk of hot surfaces, sharp edges, splinters and exposed fasteners can cause injury



**WARNING**

High voltage danger!

Arc flash and electric shock hazard.

Disconnect main power supply from the feeder before working on this unit. Proceed with caution and



always wear protective equipment per NFPA 70E before working within electrical control panel. Failure to comply can cause serious injury or death.

**WARNING**

Evaporator unit requires drain connections. Do not locate these connections above any equipment that could sustain water damage.

**NOTICE**

- Improper storage can cause unit damage. Keep the unit upright and store it indoor. Protect the unit from dampness, freezing temperatures and contact damage.
- Risk of overhead interference. The unit may be too tall to fit through a doorway. Measure the unit and doorway heights and follow the installation plans to verify clearances prior to moving the unit.
- Risk of clogged or leaking drain lines. Drain line must be inspected and maintained to ensure that drain water runs freely through the drain system. Improper installation, application and service practices can result in water leakage from the unit. Water leakage can cause severe property damage and loss of critical data center equipment. Suitable leak detection system shall be installed for the unit and water supply lines to minimize the damage.
- Risk of leaking unit coil/or piping due to freezing and/or corrosion can cause equipment and building damage.

---

### **3.0 GENERAL EQUIPMENT DESCRIPTION**

---

The Compu-Aire System 2100 air cooled Kompact series is a complete environmental control system, factory wired, tested, and specifically designed to provide temperature, humidity, and dust control for computer room installation. System 2100 is designed to provide precise temperature control by utilizing advanced digital and analog control via a programmable logic controller. Discharge air in the unit is provided by utilizing variable frequency fan blowers also known as plug or EC fans. The unit as shipped from the factory includes blower/motor package, electrical control package, and other specified special options.

---

### **4.0 RECEIPT OF UNIT AND TRANSPORTATION**

---

Upon receipt of the unit, a visual inspection is required. The unit packaging should be entirely intact and the crate should not be damaged. Transport the unit to the desired location in the upright position to avoid damaging to any external panels or internal components. Once the unit is uncrated and in the desired location, inspection of the unit for any external damage is crucial as this may be indicative of internal damage. Any signs of damage to the packaging or system panels or incomplete shipments require a claim to be filed with the shipping company. Freight damage claims are the responsibility of the receiver.

Any items designated as field installed shall be packaged inside of the unit and must be removed and installed prior to startup of the equipment.

Optional articles such as jack-stand parts, condensate pump, and remote control panel are packaged separately.

**REPORT ANY DAMAGE TO THE CARRIER. COMPU-AIRE IS NOT RESPONSIBLE FOR FILING OF ANY CLAIMS. ALL NEEDED INSPECTION AND CLAIM FILING IS THE RESPONSIBILITY OF THE RECEIVER.**

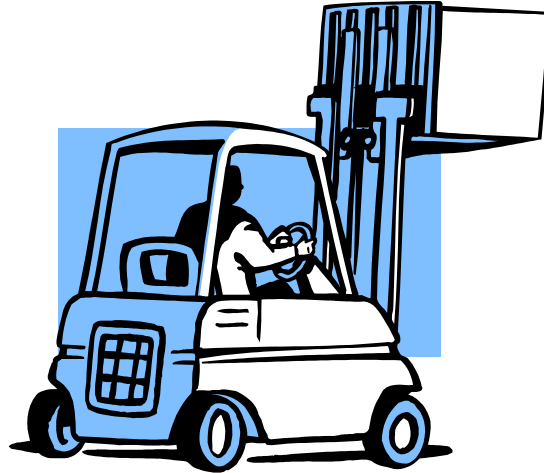

Figure 1: LOADING UNITS

---

## 5.0 LOCATING THE UNIT

---

The location of the unit shall be selected based on air distribution in the room and service access requirement. System 2100 air cooled series units are available with two air flow configurations. The down flow units are used for raised floor applications. The up flow units with plenum or duct connection are available for rooms without raised floor. Refer to unit dimension drawing for dimension and access requirements. Proper clearance is important for the unit function and access to various components for service.

Front clearance: 36"

Left clearance: 36"

Right clearance: 36"

- Install unit on leveled solid floor that can support the unit weight and vibrations.
- Securely mount the unit with floor and brace it with wall if needed.
- Install the unit closer to the largest heat load.



Air distribution is very important for proper unit operation. Air balancing is required to obtain design CFM at site. Fan speed can be adjusted from the controller as needed. Several feet of clearance must be maintained between the supply air and return air intake of the unit. In existing room, the unit supply air shall be directed towards the air intake side of the heat load. Always locate air intake of the servers and any other heat load in the cold aisle for efficient air distribution. The unit supply air shall never be directed towards the exhaust fan of any heat load in the room.

#### Down Flow Units:

Down flow units are required to be installed on floor stands. Verify that the raised floor has been properly sized for the design air flow. The raised floor shall be free of air flow restrictions. The height of the adjustable floor stand can be raised or lowered through the use of the adjusting rods. The supply air shall be directed into the cold aisles and avoid any short cycling of cold air back to the unit return air. Floor stand height for down flow models shall be selected based on unit CFM, fan size and static pressure requirement. The floor stand must be securely mounted and all locknuts must be tightened to assure rigidity. See provided floor stand drawing for installation detail.

Up Flow units: The unit may be placed directly on the sub floor. The up flow unit may have duct connection or an optional discharge air plenum. Typical up flow unit has front return configuration but optional rear return with filter box is available.



#### **WARNING**

Risk of high-speed moving parts can cause injury or death. Disconnect all local and remote electric power supplies and make sure blowers are stopped rotating before working on the unit.

Do not operate up-flow units without installing a supply air plenum, ductwork or protective guard over the blower openings.

## 6.0 UNIT DIMENSIONS

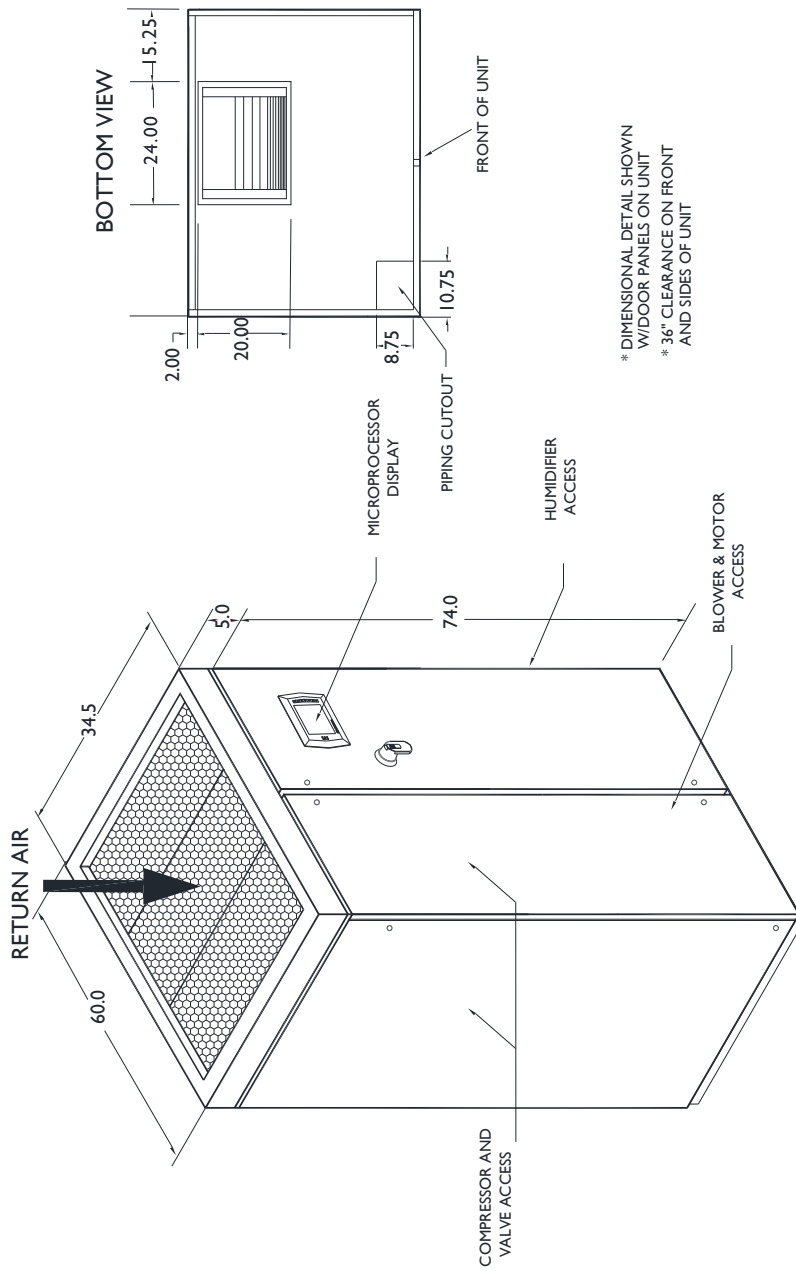

Figure 2: SYSTEM OVERVIEW

## COMPONENT IDENTIFICATION

### 6.1 Front Layout

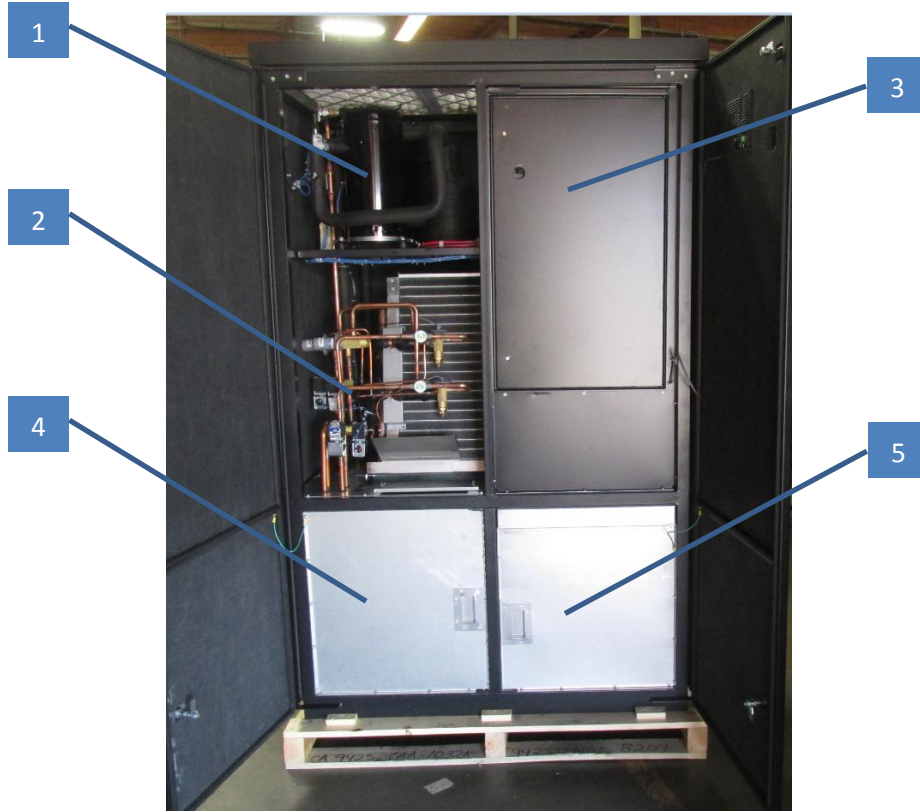

Figure 3: FRONT VIEW LAYOUT

NUMBER	NAME
1	COMPRESSORS
2	EXPANSION VALVE
3	ELECTRICAL COMPONENTS AND CONTROL PANEL BOX
4	FRONT ACCESS PIPING CONNECTION
5	FRONT ACCESS TO BLOWER MOTOR & HUMIDIFIER

Table 1: SYSTEM COMPONENTS

## High Voltage Control Panel

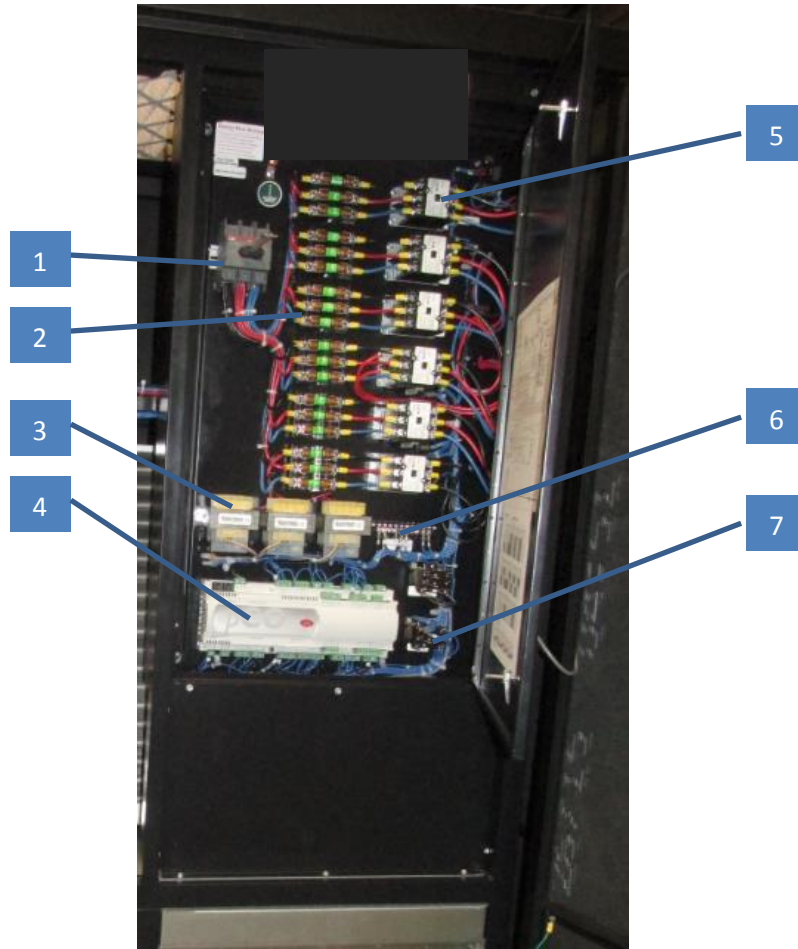

Figure 4: CONTROL PANEL LAYOUT

NUMBER	NAME
1	DISCONNECT SWITCH
2	FUSES
3	TRANSFORMERS
4	MICROPROCESSOR CONTROLLER
5	CONTACTOR
6	TERMINAL BLOCK CONNECTION
7	RELAY

Table 2: CONTROL PANEL COMPONENTS

## 6.2 Sensors



NUMBER	NAME
1	TEMPERATURE/HUMIDITY SENSOR
2	SMOKE DETECTOR
3	AIR FLOW SWITCH

Table 3: SMOKE DETECTOR

## 6.3 Low Voltage Control Panel

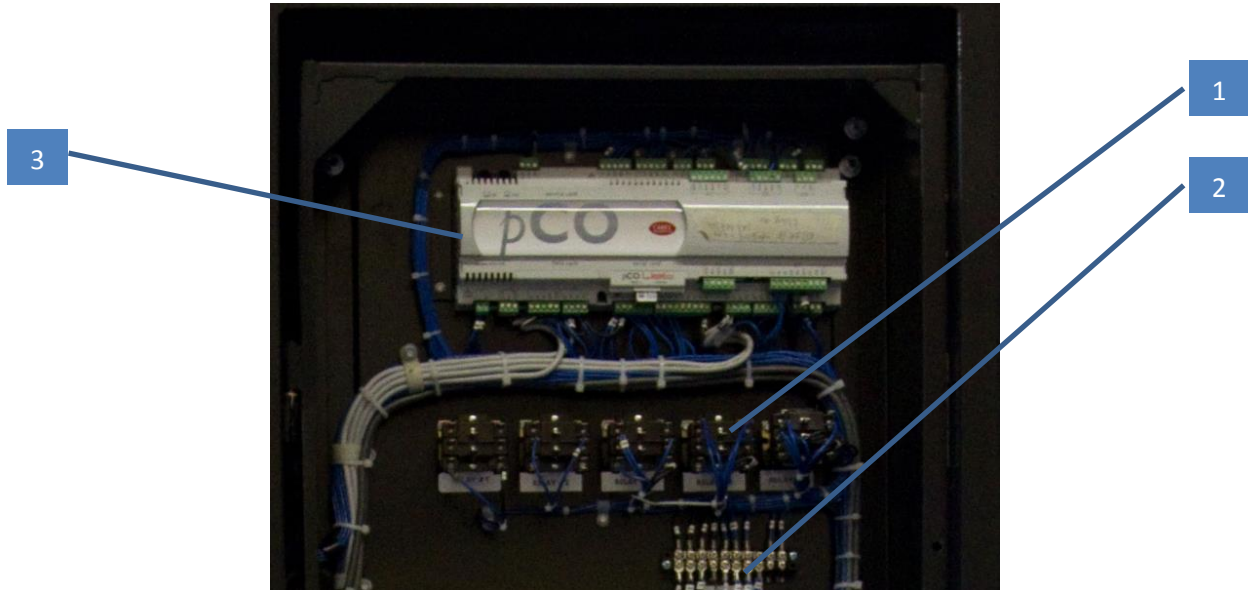

Figure 5: LOW VOLTAGE CONTROL PANEL LAYOUT

NUMBER	NAME
1	AUXILARY RELAY
2	TERMINAL BLOCK
3	PLC CONTROLLER

Table 4: LOW VOLTAGE COMPONENTS

## 6.4 Refrigeration Components

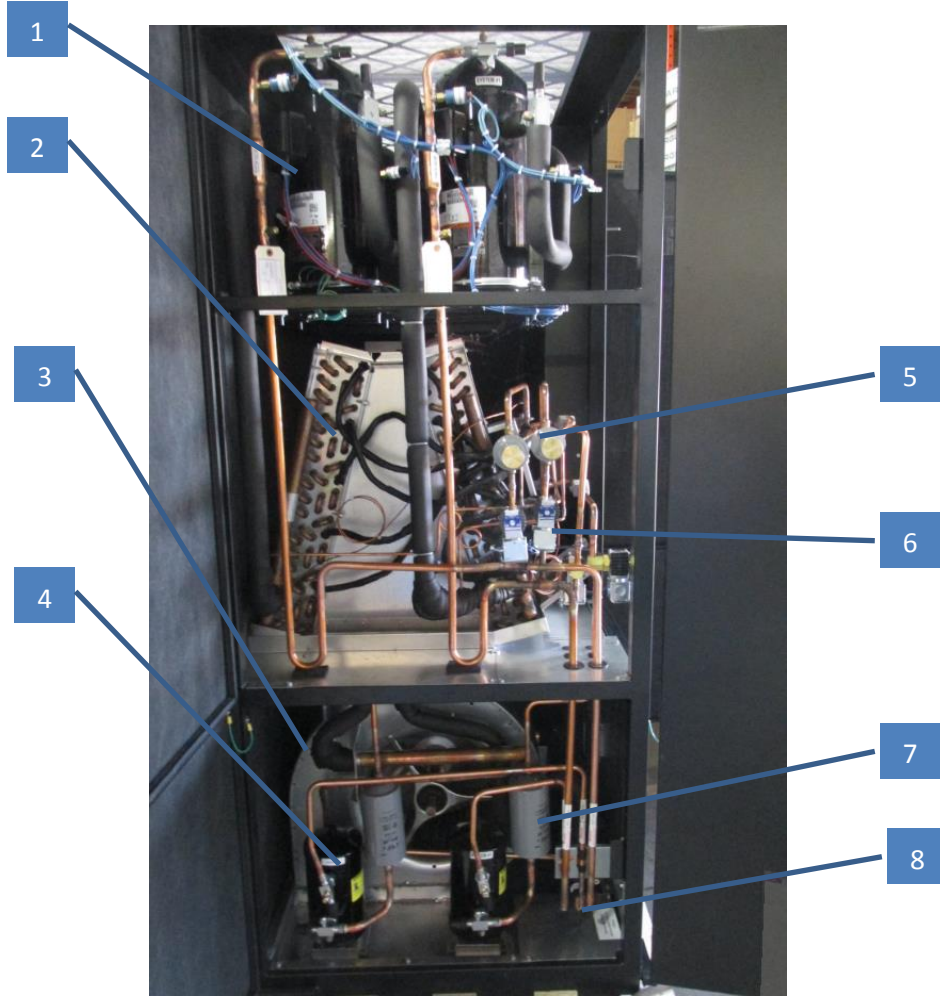

Figure 4: UNIT LEFT ACCESS

NUMBER	NAME
1	COMPRESSOR
2	COIL
3	BLOWER
4	LIQUID RECEIVERS
5	HOT GAS BYPASS VALVE
6	SOLENOID VALVE
7	FILTER DRIER
8	PIPING CONNECTION ACCESS

Table 4: REFRIGERATION COMPONENTS

## 6.5 Unit Left Access

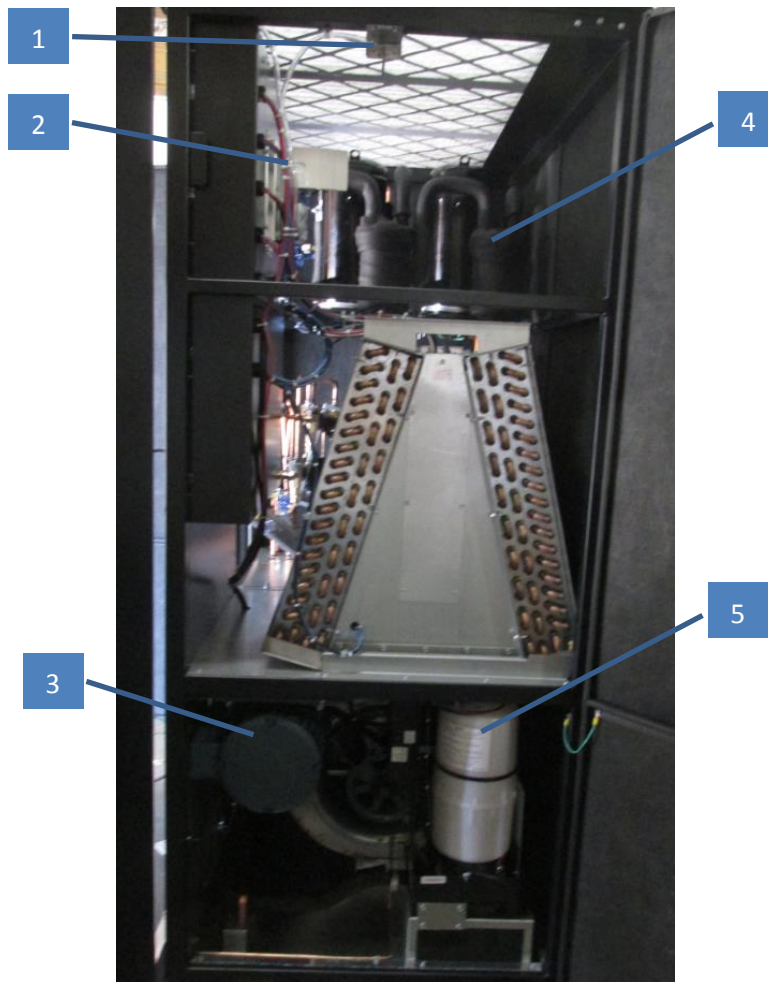

Figure 6 UNIT RIGHT ACCESS

NUMBER	NAME
1	DIRTY FILTER STATIC PRESSURE TIP
2	RETURN AIR TEMP/HUM SENSOR
3	BLOWER MOTOR
4	SUCTION ACCUMULATOR
5	HUMIDIFIER



## SYSTEM CUT-OUT JUMPER FOR EMERGENCY SHUT-DOWN

The unit is completely factory wired with self-contained controls to run without using external system cut-out. When external system cut-out is used, remove the jumper between terminal 5 and 6 and use NC dry contact of field provided system cut-out relay.

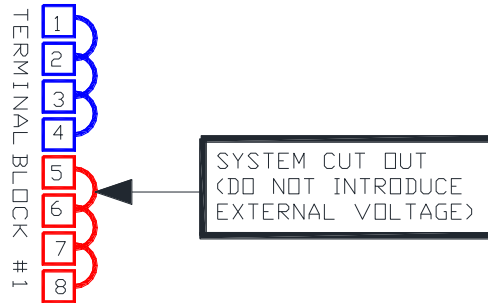

Figure 7: TERMINAL BLOCK W/ SYSTEM CUT-OUT

The system cut-out terminal on the terminals strip is for connection to a “panic button” or EPO Switch when emergency shut-down is required. The system cut-out jumper shall only be replaced by separate dry contact for each unit and **NO EXTERNAL SOURCE OF POWER SHOULD BE INTRODUCED AT THIS POINT**. The EPO relay must be installed in the unit control panel to minimize voltage drop in control circuit.

Remote ON/OFF relay shall not be used for emergency shut-down purpose. This relay is design to provide systematic shut down by the controller programming. Remote ON/OFF relays can be disabled from controller programming and unit may not shut-down in case of emergency.

---

## 7.0 REMOTE ALARMS

---

One Alarm Relay with a set of dry contact is provided for remote connection whenever the unit alarm is energized. Default setting for this alarm relay is programmed to be energized for global alarm however; it can be changed to selectable alarm to customize for specific alarms only. See controller guide for more detail on how to program this relay for selectable alarms.

If unit is provided with extra relays, see unit wiring diagram and submittal for detail.



If the unit is provided with condensate overflow sensor, the unit mounted control panel includes a condensate probe module. The condensate probe sensor shall be shipped loose for field installation. Condensate probe sensor shall be located underneath the unit where water may collect to sense any condensate overflow. To check the operation of the probe, submerge it in a cup of water. The condensate alarm should energize.

If the unit is provided with sensing cable type leak detection system, use specific manual provided by the manufacturer to install the complete system. Alarm relay dry contact from sensing cable type leak detection system can be connected to the digital input for condensate alarm of unit controller. Use 24VAC power from the unit terminal block for this alarm input.

---

## 8.0 INSTALLATION

---

### 8.1 Room Preparation

The room should be well insulated and sealed for water vapor. Door gaps and cracks should also be sealed to minimize outside air from introducing into the insulated room.

### 8.2 Location Considerations

Unit can sit on an elevated flooring while remains fully accessible. Floor stand or other support maybe used to further support the unit.

After moving the unit to the desired location, the system needs to be leveled and anchored to the floor as directed by the building design engineer, typically using wedge anchors. Prior to anchoring the unit to the floor, verify locations for Chilled Water Supply and Chilled Water Return line connections, drain line connection as well as the electrical power input locations are matching with unit location requirement. Proper electrical supply power is an absolute necessity as the unit is designed specifically for the requirements on the nameplate. All knock-out shall be provided by others in the field.

The unit is designed with draw-thru air pattern with negative pressure inside. The condensate drain connection must be installed with a proper p-trap as without it, the condensate water will not drain thus possibly causing water carry over into the air space. The p-trap must be calculated as per Figure 8: P-TRAP SCHEMATIC below. **After installation of the p-trap, verify trap operation by running the system blowers at full speed and**

adding water to the drain pan, water should drain out of the condensate pan and through the trap with supply fan running at full speed.

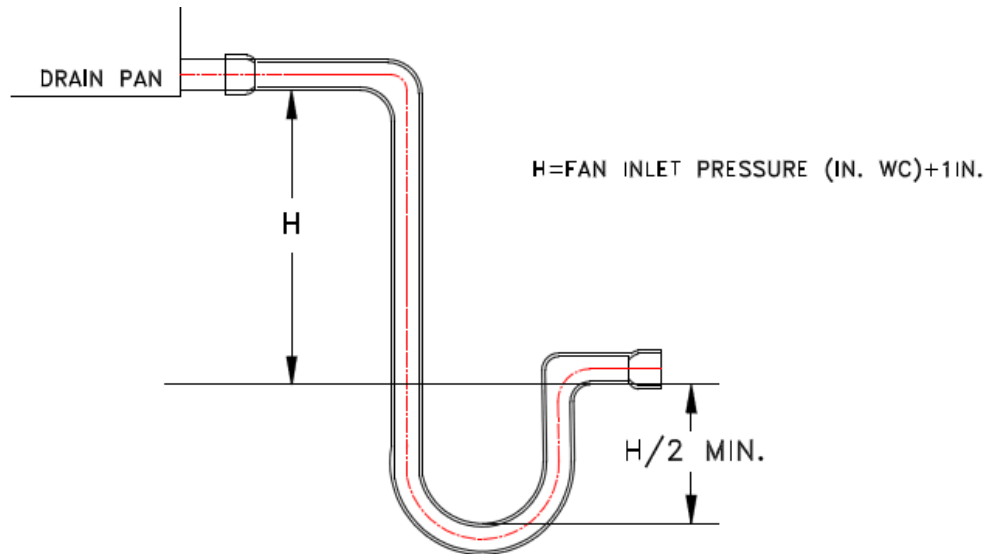

Figure 8: P-TRAP SCHEMATIC

Prior to making the electrical connections, verify the proper voltage, phase and frequency as required on the unit nameplate. Electrical connections must be made in accordance with the National Electric Code and any local ordinance which may apply. Connection should be completed using copper conductors only. The unit must have an uninterrupted or unbroken electrical ground to minimize the risk of personal injury in the case of an electrical fault. It is important the ground wire is of adequate size and is securely fastened to the ground lug in the control panel.

### 8.3 Piping

Field installed piping must be installed in accordance with local codes and must be properly assembled, isolated and supported. Refer to the submittal for piping requirements.

### 8.4 Drain Connection

Unit is provided with 3/4" copper stubs for condensate removal. These lines are marked as primary and secondary drain lines. Primary drain line is provided with built-in trap. If the location of unit does not have provision to add external P-trap on secondary line, it must be capped-off. It is recommended that unions be installed in each line to permit

ready disconnection from the unit for easy cleaning. Where local codes permit, PVC pipe may be used for drain lines. It is important that the drain line used for drain lines. It is important that the drain line installed with sufficient slope to permit easy draining. Drain lines should have a pitch away from the unit not less than 1/4" for each 10 feet of run. Do not reduce the size of the drain line.

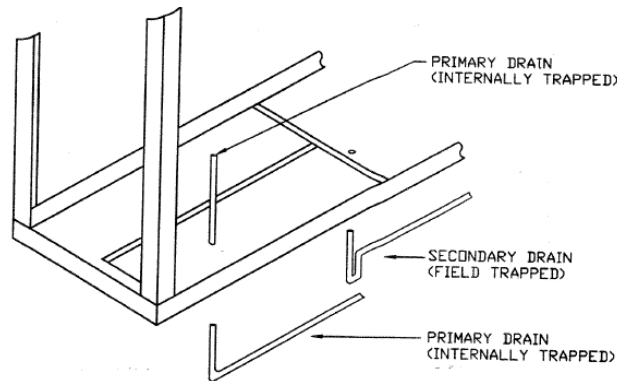

Figure 9: DRAIN CONNECTION

A secondary drain connection is provided to from the bottom pan of the unit. Secondary drain line provides drain connection from the base pan of the unit that is the lowest point in the unit. The secondary drain connection is 3/4" stub and external P-trap is required for this drain. **If secondary drain line is provided with the unit but it is not connected to the building drain, it must be capped off.**

On some applications were a floor sink or other means of condensate disposal is not available, a condensate pump of adequate size should be used. There are several condensate pumps available complete with built in floats for automatic condensate removal. The correct choice of pump depends greatly on the pressure head (vertical riser) that must be overcome. In some instances, where the head is higher than pump head capacity, two pumps pipes in series may be necessary. A check valve must be installed at the discharge side of all condensate pumps to reduce short cycling.

## 8.5 Refrigeration Piping

It is of the greatest importance that all refrigerant piping be cleaned and free from dirt and moisture. One drop of water in a refrigerant system will greatly deter the operation and efficiency of the system. Upon installation, all open ends

of piping should be sealed to prevent condensation from accumulating inside. (If it is not to be completed during the day). This avoids future problems, malfunctions and corrosion.

It is suggested that hot gas and liquid return lines be silver soldered, using one of the many types, such as silfoss, etc. Absolutely avoid soft solders such as 50/50 or 95/5. Use a flow of dry nitrogen through the piping while being soldered. (To eliminate formation of a copper oxide scale on the inside of the piping).

To reduce noise and pulsations, the air cooled systems are to be field provided with hot gas mufflers. Extreme care and planning must be exercised in running the refrigerant lines; they must be provided with proper isolation by the use of an Arma-Glex or rubber bushing on the supports. Under no circumstances should hot gas lines be laid on steel ceilings, or metal supports without a type of isolation or protection from vibration, which can possibly cause damage to the refrigerant lines.

## **8.6 EVACUATION PROCEDURES**

**CAUTION: PULL ALL FUSES EXCEPT MAIN FAN AND TRANSFORMER FUSES.** To reduce the possibility of non-condensables in the refrigerant system during charging, the solenoid valves must be open and a vacuum must be pulled on both the suction side and the discharge side of the compressor.

### **PROCEDURE FOR DEHYDRATION - METHOD #1**

- 1) Open all disconnect switches.
- 2) Pull all fuses except main fan and transformer fuses.
- 3) Turn disconnect ON
- 4) Start the main fan by pushing the main fan switch.
- 5) Check amperage on main fan and make sure it does not exceed FLA (full load amps).
- 6) Check fan rotation and correct if necessary.
- 7) Set thermostat at 40°F.
- 8) Proceed with paragraph #4 in procedure #2.

### **PROCEDURE FOR DEHYDRATION - METHOD #2**

By using a separate control voltage transformer having an output of 24 volts at 40 VA, the solenoid can be energized without starting the unit.

- 1) Turn all power OFF to the unit.
- 2) Remove all fuses including main fan and transformer fuses.
- 3) Connect the external transformer to the solenoid valves.
- 4) Evacuate the system in accordance with the following procedure:

Connect the refrigeration gauges on circuits #1 & #2 at both the suction and discharge service valves.

Start with circuit #1 and open all service valves. Place in circuit #1, 150 psig of DRY NITROGEN with a tracer of freon for the purpose of leak checking. With pressure in circuit #1, open the discharge and suction valve on compressor #2. If pressure increases in #2, the system is cross circuited and must be re-checked for proper piping. If there is no pressure increase, place 150 psig of DRY NITROGEN with a tracer of freon in circuit #2 and leak test.

After completion of leak testing, release test pressure & pull a vacuum on the system. Leave this pulled down for approximately 4 hours and re-check the gauge reading. If it has not changed purge with freon, pull another vacuum of 250 microns, leave on for 2 hours and re-check the gauge readings. Purge with freon and re-pull the vacuum of 250 microns (9.842 in. hg.) or less. After the completion of this step, fill the system with Freon vapor until pressures have equalized in the liquid and discharge lines.

## **8.7 Charging Procedure**

Turn the disconnect "ON" and check the evaporator fan for proper rotation.

Set the thermostat to 40°F to insure that the solenoid valves are open during the charging procedure. Connect the refrigerant gauges to the refrigerant drum purging the hoses to remove non-condesables.

Add refrigerant vapor to the suction side of the compressor to eliminate short cycling of the compressor. The low pressure switch can be manually energized to expedite the charging.

As the system builds head pressure, the condenser fan will start rotating slowly. The Fan Speed Control motor will not be energized until a sufficient head pressure has been developed during the charging of the unit.

Charge the unit until the sight glasses on the liquid lines in the compressor section clear. Watch the sight glasses for a period of 10 minutes to insure that no bubbles re-appear.

## **8.8 Liquid Charge**

After the final vacuum has been pulled on the systems, liquid refrigerant may be placed in the receivers. This is accomplished by the following procedure:

- 1) Make sure the unit is off and that the solenoids are closed.
- 2) Connect a set of manifold gauges to the refrigerant drum and to the receiver at the rotolock adapter.
- 3) Purge the refrigerant hoses so that no non-condensables will enter the systems.
- 4) Open the refrigerant drum so that the liquid will flow from the drum to receiver.
- 5) Open the roto-lock valve and allow the refrigerant to flow into the receiver.
- 6) Close the roto lock valve and disconnect gauges.
- 7) Start the compressor.

## **8.9 Vapor Charge**

- 1) After the dehydration procedures have been followed, replace the fuses in the condenser fan compressors and transformer circuits.
- 2) Connect hose from drum to suction port of the compressor, purge hose so that no non-condensables are in the hose.

- 3) Start the compressors check the level in the sight glass. If the level has lowered, add additional freon to maintain the sight clear. After charging is complete, reset the high pressure switch.

Approximate charge required per circuit:

As recommended by ASHRAE MANUAL.

Total Charge = Basic Charge + Liquid Line Based on Hermetic Compressor Line and Refrigerated Liquid at 100F.

### **8.10 Leak Testing**

No installation is complete until the entire system has been thoroughly checked for leaks. This includes water tubing, humidifier make-up water, and condensate lines (if provided).

### **8.11 How to Save the Refrigerant Charge**

The process of opening a refrigerant circuit of the Compu-Aire System 2100 and saving the refrigerant charge of the system to be opened requires only a few more minutes than does blowing the refrigerant charge. **Intentionally blowing the charge is illegal.**

The procedure for saving the refrigerant charge is as follows:

- 1) Open disconnect switch.
- 2) Pull fuses on system not to be opened.
- 3) Install manifold on the receiver at each rotolock valve, using the high pressure gauge and the charging hose.
- 4) Purge the hoses to remove any con-condensables.
- 5) Start the unit and set the thermostat at 40 degrees F; this will start the compressor.
- 6) Return to the receivers.
- 7) Backseat the rotolock valves on the system being pumped down. Open gauge and rotolock valve on the other system.

- 8) During this procedure, watch the gauge pressure to prevent the receiver from over-filling. If the gauge pressure starts to rise, do not let the pressure exceed setting on pressure relief device located on the receiver.
- 9) Open the rotolock valve of the system, release vapor pressure present and make necessary repairs.
- 10) Evacuate the system. After evacuation is complete, the liquid can be transferred back into the proper system, through the manifold gauge.

## 8.12 Electrical Connection

**The unit is completely factory wired with self-contained controls.**

**IMPORTANT** - Before proceeding with the electrical connections, make certain that the volts, hertz and phase correspond to that specified on the unit rating plate. Also, check to be sure that service provided by the utility is sufficient to handle the additional load imposed by this equipment. Refer to the unit rating plate for equipment electrical requirements. The attached wiring diagram shows the proper high and low voltage field wiring.

Make all electrical connections in accordance with National Electrical Code and any local code ordinances that may apply. **USE COPPER CONDUCTORS ONLY.**

**WARNING** -- The unit cabinet must have an uninterrupted or unbroken electrical ground to minimize personal injury if an electrical fault should occur. It is important that an electrical ground wire of adequate size can be connected to the ground lug provided inside the control box.

Supply voltage at the unit must be within  $\pm 10\%$  of the voltage indicated on the nameplate for a dual voltage rating, supply voltage must be within 5% from the lower nameplate rating and within 10% from the higher rating. Phase to phase imbalance must not exceed 3%. Contact your local utility company for correction of improper line voltage. Improper electrical power supply may cause premature failures and void unit warranties.

The system cutout terminals on the terminal strip are for connection to a "panic button" or remote shut-off if required. This should only be connected to a switch and **NO EXTERNAL SOURCE OF POWER SHOULD BE INTRODUCED AT THIS POINT.** The conductors should be sized depending on the length of run and the number of control transformers used in the unit. **Maximum voltage drop must not exceed 1 volt.** Each control transformer draws



approximately 3 amps @ 24 V. For long runs where the conductor size becomes too large, an interlocking relay (field provided) should be used.

**A dry contact (24 volts rating) is provided for terminals for a remote alarm connection.**

If the control panel includes a condensate probe, make sure it is mounted below the unit against the floor area where water may collect. To check the operation of the probe, submerge it in a cup of water. The condensate alarm should energize.

---

## **9.0 STARTUP AND TEST PROCEDURE**

---

### **A. With all power to unit off – Check that all wiring is correct**

Check that properly sized fuses are installed in the disconnect switch. Correct fuse size and minimum circuit ampacity are listed on the unit nameplate. Now, check the wiring connections in the Main Control Panel to see if they are tight. It is best that this be checked prior to operating the machine. After checking, close the Main Control Panel cover and proceed as follows:

Solid-State Control Panel - With the system switch in the "OFF" position, apply power to the unit. The "Power On" light should illuminate.

### **B. Check for correct phasing**

The equipment should now be checked for correct phasing required to make the blower motor turn in the correct directions. For this test it is necessary to open the front access panel or the right side doors of the unit to observe the blower and blower motor. Now, momentarily switch the system switch to the "ON" position and then back to "OFF". The blower will have started and it is therefore possible to determine rotation. On Compu-Aire units, the blower should be rotating in a CLOCKWISE direction in the down flow units and COUNTER CLOCKWISE in the up flow units, looking in the right side of the unit. Heaters and humidifiers are not affected by phasing.

### **C. Blower speed adjustment**

Adjustment of the air flow may be desired based on air balancing requirement. The air flow must be checked and adjusted for minimum and maximum CFM requirements. The air flow can be readily adjusted with the minimum and maximum output voltage limit from the controller. After the unit has been started and the air flow properly adjusted, check the blower motor current to ensure that the motor is not overloaded. Any time the blower speed is increased, the blower motor current should be checked. If a field adjustment is made, the motor should run for at least one hour at maximum design room temperature to see if motor trips on internal overload.

**D. No air flow & Clogged filter adjustment**

The "No Air Flow" light and alarm should be checked prior to the completion of the installation. Although the control adjusted at the factory, varying local conditions make it impossible to provide accurate pressure adjustments.

To check the filter pressure switch, let the unit operate on cooling for about 30 minutes. This will allow the evaporator coil surface to become wet. The air pressure differential switch is provided with adjustable knob. Set the knob to desire pressure drop for dirty filter and verify the Dirty Filter alarm. With the unit cooling and filters in place, block off approximately 75% of the air intake. If the sensing device is correctly adjusted, the "Clogged Filter" alarm should energize; the sensing device should have just turned on the alarm at the 75% blocked inlet condition. An Air Flow Sail switch is also provided at the discharge side of the blower and will activate the No Air Flow malfunction light and alarm.

Similar to the clogged filter switch, adjustment may be necessary for the no air flow switch(s). The loss of airflow switch is wired in the normally closed position to open on airflow and the dirty filter switch is wired to the normally open position and set to close with dirty filter. Adjustment can be made by removing the top cover and turning the dial to the proper pressure. See Figure 9 below.



Figure 10: AIR PRESSURE DIFFERENTIAL SWITCH

---

## 10.0 GENERAL MAINTENANCE

---

General maintenance must be performed in regular intervals to provide continued operation of the entire unit. The maintenance intervals must be determined site specifically. Use the maintenance checklist at the end of this manual when performing maintenance. Typically, air filters should be replaced no less than two times per year.

### FILTERS

1. The filters should be checked and changed periodically. When they become dirty, an alarm is activated the filter pressure switch. If the filters are dirty, they must be changed for efficient operation of your system. To check the alarm indicator, cover approximately 75% of the return air opening; the alarm should energize. If the alarm energizes prematurely or does not energize when it should, adjust the filter switch. All doors to machine should remain closed before determining whether an adjustment is necessary.
2. Spare filters should be kept in stock. Filters should be checked monthly and replaced if necessary.

---

## 11.0 TROUBLESHOOTING GUIDE

---

Complaint	Problem	Symptom	Action
1. System does not run.	No 24VAC supply voltage.	Power LED is not on.	Check circuit breaker in system 24VAC circuit and reset if necessary. Check System cutout switch. Test for 24VAC at pins 1 and 2 of MCP. If no voltage check machine wiring. Other-wise, if voltage replaces MCP.
	System is not turned on.	Power LED is on but, System LED is off.	Press the On button on the MCP. If the system does not start and the display is blank, replace the MCP.
	Bad or locked up MCP.	Display is blank, shows erroneous characters or does not change messages.	Press Off button on MCP then press On button. If the system does not start or if the display still shows erroneous information, replace the MCP.

Complaint	Problem	Symptom	Action
2. Nothing is visible on the display or is barely visible.	Display contrast is adjusted too low.	Power is on and system is running okay. But, nothing is visible or is barely visible on display.	Refer to the section MCP Circuit Adjustments, in this guide. Adjust display contrast for best visibility. The display will not be visible unless light is directed into it (it does not have its own light source).
3. Temperature or humidity displayed is wrong.	Sensor circuits are out of calibration.	Displayed value(s) are wrong by a few increments.	If the value is wrong by a few degrees or percent when compared to an accurate measuring instrument, then try recalibrating the sensor circuits (see the section MCP Circuit Adjustment, in this guide).
	Wiring to sensor circuit board(s) are loose or broken.	Display shows very high or low values or values that change erratically.	Check all wiring between the sensor circuit board and the MCP for loose connections. If the values

Complaint	Problem	Symptom	Action
			<p>don't change and they seem to be at an extreme high or low, test for 24-VAC at the sensor board. Test for continuity between Temp and Hum on the sensor board and pins 9, 14, and 16 on the MCP. If tests fail repair or replace wiring to sensor boards. If tests are okay, swap connections between pins 14 and 16 and observe whether display tracks each okay. If it does, replace the sensor. If it doesn't, replace the MCP.</p>

<b>Complaint</b>	<b>Problem</b>	<b>Symptom</b>	<b>Action</b>
4. Sensor(s) do not adjust into range.	Circuits on MCP are out of calibration.	Displayed values change but, adjustments to the sensor circuit board do not bring the temperature or humidity displayed to the actual value.	See the section, Adjusting MCP Circuits in this guide. If those adjustments fail and instructions for item 3 above have been followed, contact Compu-Aire for further assistance.
5. System does not cool or does not cool sufficiently.	Control parameters are not set correctly or are not set as expected.	System seems to function okay otherwise.	Refer to the section in this guide, Environment Control Settings, and check that all parameters are set correctly.
	Compressor is not running because of high or low pressure failure.	Display shows compressor failure alarm. Alarm LED is on.	Determine cause of high or low pressure failure and remedy. Press Reset button on MCP.

Complaint	Problem	Symptom	Action
	Compressor is not running because of loose or broken wiring.	Display shows DX cooling is on and there are no compressor failure alarms.	Test for 24VAC at pin 17 and 27 of MCP terminal block while shows DX cooling. If voltage, check wiring back to compressor contactor. If no voltage at pin 27, check wiring back to 24VAC transformers in system. If voltage at pin 27 but not at 17, replace MCP.



Complaint	Problem	Symptom	Action
	Chilled water valve is not opening because of loose or broken wiring.	Display shows chilled water cooling is on or economy cooling is on but, the valve is closed.	Test for 24VAC at valve motor. Check continuity between pins 3 and 12 of MCP and valve motor. If continuity, test for 5VDC to 10VDC between pin 1 and 12 of MCP. If no voltage, replace MCP.
	DIP switches on MCP are set incorrectly.	After setting a temperature set point sufficiently lower than room air, and waiting one minute, the display never indicates cooling is on or shows the wrong type cooling.	Refer to the section in this guide, DIP Switch Settings, and check that the compressors are enabled for DX systems or disabled for chilled water systems.
6. System does not heat or does not heat sufficiently.	Control parameters are not set correctly or are not set as expected.	System seems to function okay otherwise.	Refer to the section in this guide, Environment Control Settings, and check that all control parameters are set correctly.
	Humidifier is on.	Display shows the humidifier is operating.	The heaters don't operate while the humidifier is on. Refer to the section, Environment Control Settings, and check

			that all control parameters are set correctly.
	DIP switches on MCP are not set correctly.	After setting a temperature set point sufficiently higher than room air, and waiting one minute, the display never shows any stage of heating.	Refer to the section in this guide, DIP Switch Settings, and check that the heaters are enabled.
	Heaters are not on because of loose or broken wiring.	Display shows stage one or stage two heating but the heaters are not on.	Test for 24VAC at pin 27 of the MCP terminal connector. Test at pin 30 only if stage two is off. Test at both 30 and 33 if stage two is on. If no voltage at pin 27 or if voltage at each, check back to system terminal block and heater contactors. If voltage at pin 27 but, no voltage at pin 30

Complaint	Problem	Symptom	Action
			Or pin 33 if stage two is on, replace the MCP.
7. System does not humidify or does not do so sufficiently.	Control parameters are not set correctly or set as expected.	System seems to function okay otherwise.	Refer to the section, Environment Control Settings, and check that all control parameters are set correctly.
	Loose or broken wiring in low voltage circuits or bad MCP.	Display shows humidification operating but, the humidifier is not on.	Test for 24VAC at pins 4 and 5 of the MCP. If no voltage, check wiring back to system. If volt-age at pin 4 but not 5 or vise-versa, replace the MCP.
8. System does not de-humidify or does not do so sufficiently.	Control parameters are not set correctly or are not set as expected.	System seems to function okay otherwise.	Refer to the section, Environment Control Settings, and check that all control settings are correct.
	Compressors or chilled water valve (depending on type system) is not operating.	Display shows dehumidification but, compressors are not running or, for chilled water systems, the valve is not open.	Check all items under 5 above.

<b>Complaint</b>	<b>Problem</b>	<b>Symptom</b>	<b>Action</b>
9. Display shows messages that don't make sense for this machine.	DIP switches on MCP are set incorrectly.	Display shows function messages for equipment not installed.	Refer to the section in this guide, DIP Switch Settings, and make sure the switches are set correctly.
10. System occasionally forgets control settings.	Battery is dead.	If the system is turned off for a few minutes and then turned on again, the set points are not as they were.	The battery on the MCP has an expected life of at least 5 years. Contact Compu-Aire for assistance in replacing the battery.
	Excessive noise on the power supply.	There has been a thunder storm in the area or there was a power outage or brown-out.	Random problems could be attributed to noise on the power source caused by machinery being switched on and off, power outages or thunder storms. These kinds of problems can be very difficult to identify. Make sure all wiring

Complaint	Problem	Symptom	Action
			connections are secure and that contactors do not chatter when switched. Check that the system ground is properly connected to an earth ground.
11. System is on but, no-thing is operating. The blower is off.	No air flow, fire stat, water on floor or smoke detector alarm is activated.	The display shows one or more of these alarms and the Alarm LED is on.	The system is automatically shut down if any of these conditions occur. Determine what the cause is and remedy. Then, press the Reset button on the MCP.

---

## 12.0 REFERENCE DOCUMENTS

---



### MAINTENANCE CHECKLIST

Inspection Date \_\_\_\_\_

Job Name \_\_\_\_\_

Unit Model # \_\_\_\_\_

Unit Serial Number # \_\_\_\_\_

Room Temperature \_\_\_\_\_ ° Humidity \_\_\_\_\_ %

Ambient Temperature \_\_\_\_\_ °

#### Filters

- \_\_\_ 1. Check/replace filters
- \_\_\_ 2. Grille area unrestricted
- \_\_\_ 3. Wipe section clean
- \_\_\_ 4. Coil clean

#### Blower Section

- \_\_\_ 1. Blower wheel(s) free of debris
- \_\_\_ 2. Check belt tension and condition (replace if needed)
- \_\_\_ 3. Check bearings
- \_\_\_ 4. Check sheave/pulley (replace if worn)
- \_\_\_ 5. Check motor mount
- \_\_\_ 6. Motor amp draw L1 \_\_\_\_\_ L2 \_\_\_\_\_ L3 \_\_\_\_\_
- \_\_\_ Compare measured amp draw to nameplate rating

#### Reheat

- \_\_\_ 1. Inspect elements
- \_\_\_ 2. Check wire connections (inside reheat box)
- \_\_\_ 3. Reheat amp draw \_\_\_\_\_ #1 \_\_\_\_\_ #2 \_\_\_\_\_ #3

#### Steam Generating Humidifier

- \_\_\_ 1. Check drain valve/drain lines/trap for clogs
- \_\_\_ 2. Check water make-up valve and all hoses for leaks
- \_\_\_ 3. Clean strainer
- \_\_\_ 4. Replace humidifier bottle if necessary

- \_\_\_ 5. Check operation of humidifier
- \_\_\_ 6. Humidifier amp draw L1 \_\_\_\_\_ L2 \_\_\_\_\_ L3 \_\_\_\_\_

**Condensate Pump**

- \_\_\_ 1. Check for debris in sump
- \_\_\_ 2. Check operation of float(s) (free movement)

**Electrical Panel**

- \_\_\_ 1. Check fuses
- \_\_\_ 2. Check contactors for pitting
- \_\_\_ 3. Check all wire connections

**Controls**

- \_\_\_ 1. Check/Verify Control Operation (Sequence)
- \_\_\_ 2. Check operation of the airflow switch
- \_\_\_ 3. Check setting/operation of the clogged filter switch
- \_\_\_ 4. Check/test changeover device(s)
- \_\_\_ 5. Check/test water detection device(s)

Notes \_\_\_\_\_  
\_\_\_\_\_  
\_\_\_\_\_  
\_\_\_\_\_  
\_\_\_\_\_  
\_\_\_\_\_  
\_\_\_\_\_  
\_\_\_\_\_  
\_\_\_\_\_  
\_\_\_\_\_  
\_\_\_\_\_  
\_\_\_\_\_  
\_\_\_\_\_  
\_\_\_\_\_  
\_\_\_\_\_  
\_\_\_\_\_  
\_\_\_\_\_  
\_\_\_\_\_  
\_\_\_\_\_  
\_\_\_\_\_  
\_\_\_\_\_

Signature \_\_\_\_\_  
Company \_\_\_\_\_

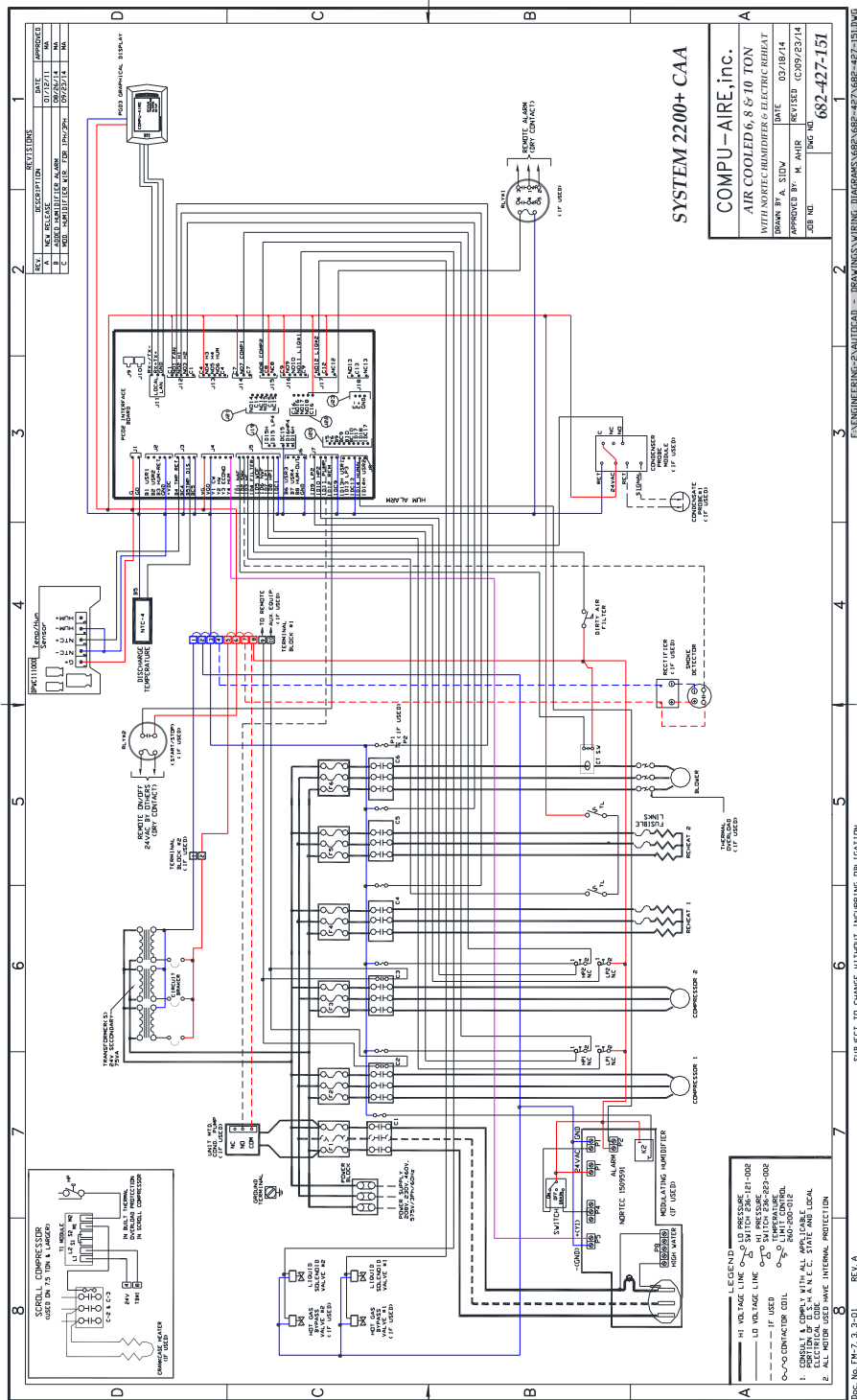

Figure 11: TYPICAL SCHEMATIC





8167 Byron Rd., Whittier, CA 90606

PH (562) 945-8971 FAX (562) 696-0724

## STANDARD ONE YEAR WARRANTY

Job Name: \_\_\_\_\_ Job No. \_\_\_\_\_ Date: \_\_\_\_\_

We warranty this Compu-Aire, Inc. computer room unit to be free from defects in material and workmanship; our obligation being limited to repairing or replacing at our factory any part (except as noted below) within one year from the date of shipment to the original purchaser. Parts to be returned to us PREPAID. Proof of start-up date must be submitted to the factory.

This warranty is effective only if the unit has been installed in accordance with our instructions and connected to proper and adequate electric, water and drain services, correctly dehydrated and placed into operation by a competent service representative.

Fan motor compressor warranty is covered by original manufacturer's warranty and any repair or replacement should be made by the local authorized service facility as listed the telephone book.

Maintenance and service such as replacing filters, humidifier cylinder, infra-red lamps, float valve assemblies, belts, cleaning, lubrication, calibration and adjusting are NOT INCLUDED in this warranty.

Replacement or repair parts shall be shipped from the factory pre-paid and invoiced for the full amount. Upon receipt of warranted parts within 30 days with prepayment of the component and which our inspection discloses the parts are defective, and show no signs of misuse, alterations, or abuse, full credit will be issued.

Compu-Aire, Inc. does not assume any responsibility for the labor expense for changing defective parts or replacement of any refrigerant or other cooling medium such as glycol etc.

All parts and goods are thoroughly inspected and packed to meet the requirements of railroad freight classifications bureaus, and under standard shippers risk, when they leave our factory. SHOULD GOODS ARRIVE DAMAGED, call the agents attention to damage, and have same noted on freight bill. For concealed damage, demand immediate inspection from agent of the shipping company and insist on a notation being made on freight bill.

<b>Purchaser-User</b>	<b>Model Number</b>	<b>Serial Number</b>
		<b>Serial Number</b>
		<b>Serial Number</b>
		<b>Serial Number</b>



#### TECHNICAL SUPPORTS

[www.compu-air.com](http://www.compu-air.com)

Tel: (562) 945-8971

Fax: (562) 696-0724

#### UNITED STATES OFFICE

**Compu-Aire, Inc.**

8167 Byron Rd.

Whittier, CA 90606

While every precaution has been taken to ensure the accuracy and completeness of this literature, Compu-Aire assumes no responsibility and disclaims all liability for damages resulting from use of this information or for any errors or omissions.

© 2014 Compu-Aire, Inc

All rights reserved throughout the world. Specifications subject to change without notice.

