



COMPU-AIRE INC.

Specialized Environmental Air Conditioning Systems

Compu-Kool III

Split Floor Mount Systems
2-5 Ton



All computers are highly sensitive to their environment. To function efficiently, they require specific temperature, humidity, and filtration conditions. Failure to meet these specified conditions can result in distorted or lost data and even complete shutdown of computer services.

Compu-Aire understands the special environmental control needs of both main-frame and mini-computer rooms.

Today, Compu-Aire has successfully installed units at defense, government, industrial, and commercial facilities. Compu-Aire's modern manufacturing facilities and experienced technicians are capable of original design and production to fit the needs of the customer, however technically complex.

Compu-Aire's unique air conditioners not only keep pace with rapidly changing computer technology, but offer the highest degree of reliability in component and system operation, for continued service 24 hours a day, 7 days a week.

Compu-Aire offers total environmental air protection for any sizeable computer investment.



CK A 2 1 2

Compu-Kool

Nominal Tonnage

2 - 2 Ton

3 - 3 Ton

5 - 5 Ton

Voltage

2 - 208/230

3 - 380

4 - 460

5 - 575

Phase

1 - 1 phase

3 - 3 phase

Type

Air Cooled - A

Water Cooled - W

Glycol Cooled - G

Evaporator Section Only - W

Centrifugal Blower Air Cooled Condensor - ACCB

Centrifugal Blower Type Dry Cooled Condensor - DCCB

Centrifugal Fan Condensing Unit - CFCU

Propeller Fan Condensing Unit - PFCU

Water Cooled Condensing Unit - WCCU

COMPU-KOOL

Split Floor Mount Systems

Easy front, left or right side maintenance access.

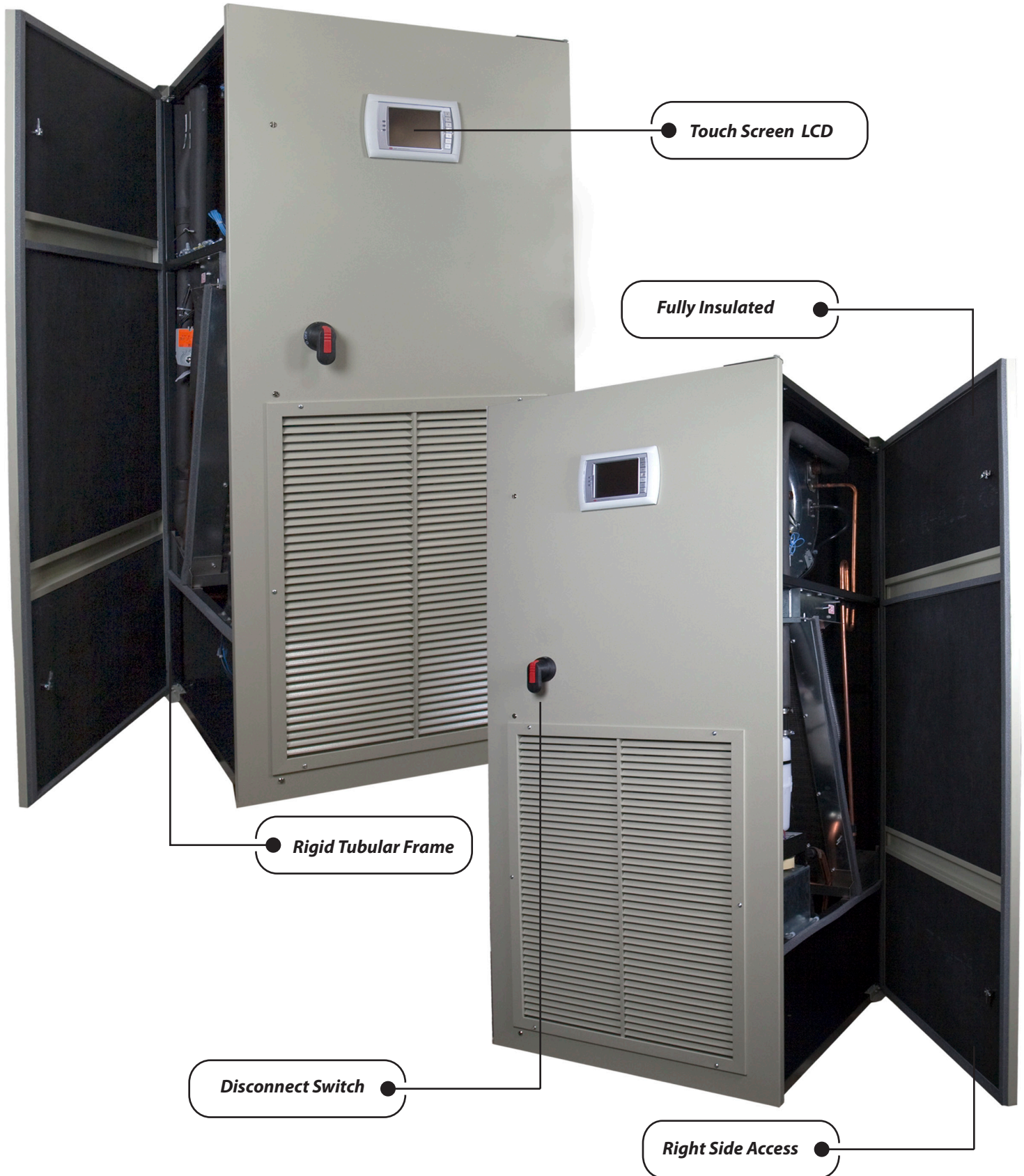

● **Touch Screen LCD**

● **Fully Insulated**

● **Rigid Tubular Frame**

● **Disconnect Switch**

● **Right Side Access**

AVAILABLE SYSTEMS

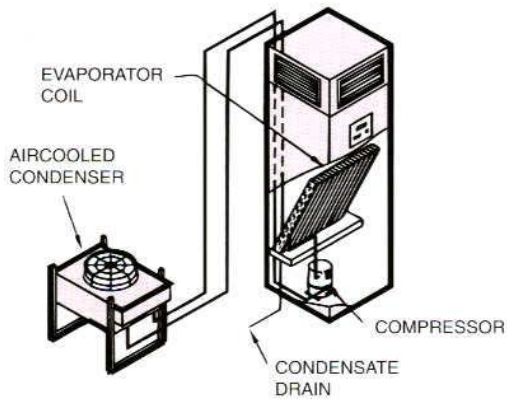

**SELF CONTAINED
AIR COOLED SYSTEM CKA WITH
OUTDOOR CONDENSER**

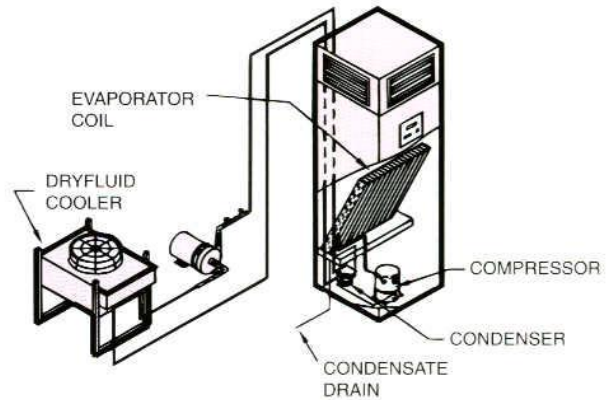

**SELF CONTAINED
GLYCOL COOLED SYSTEM CKG WITH
OUTDOOR DRYFLUID COOLER**

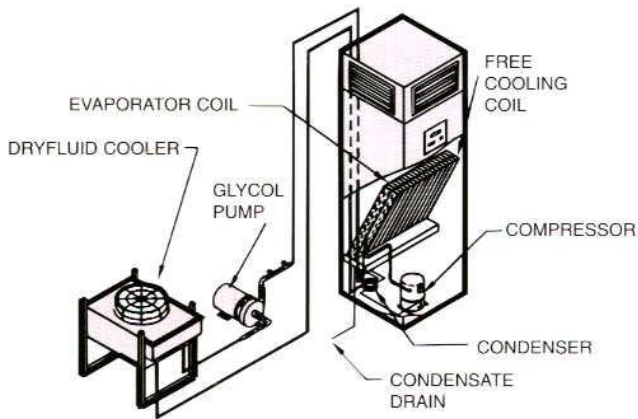

**SELF CONTAINED
GLYCOL COOLED WITH ENERGY-MISER SYSTEM CKG-
EM WITH OUTDOOR DRY FLUID COOLER**

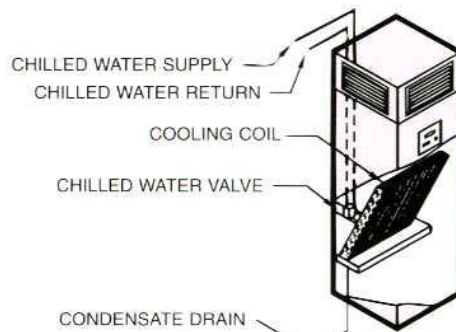

**SELF CONTAINED
CHILLED WATER SYSTEM CKC**

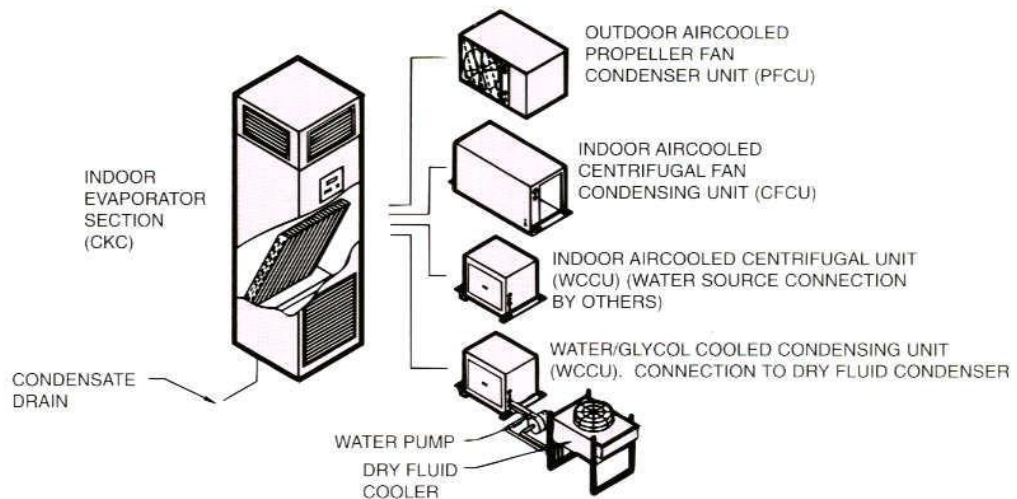

SPLIT SYSTEM-ANY COMBINATION

Down Flow Model

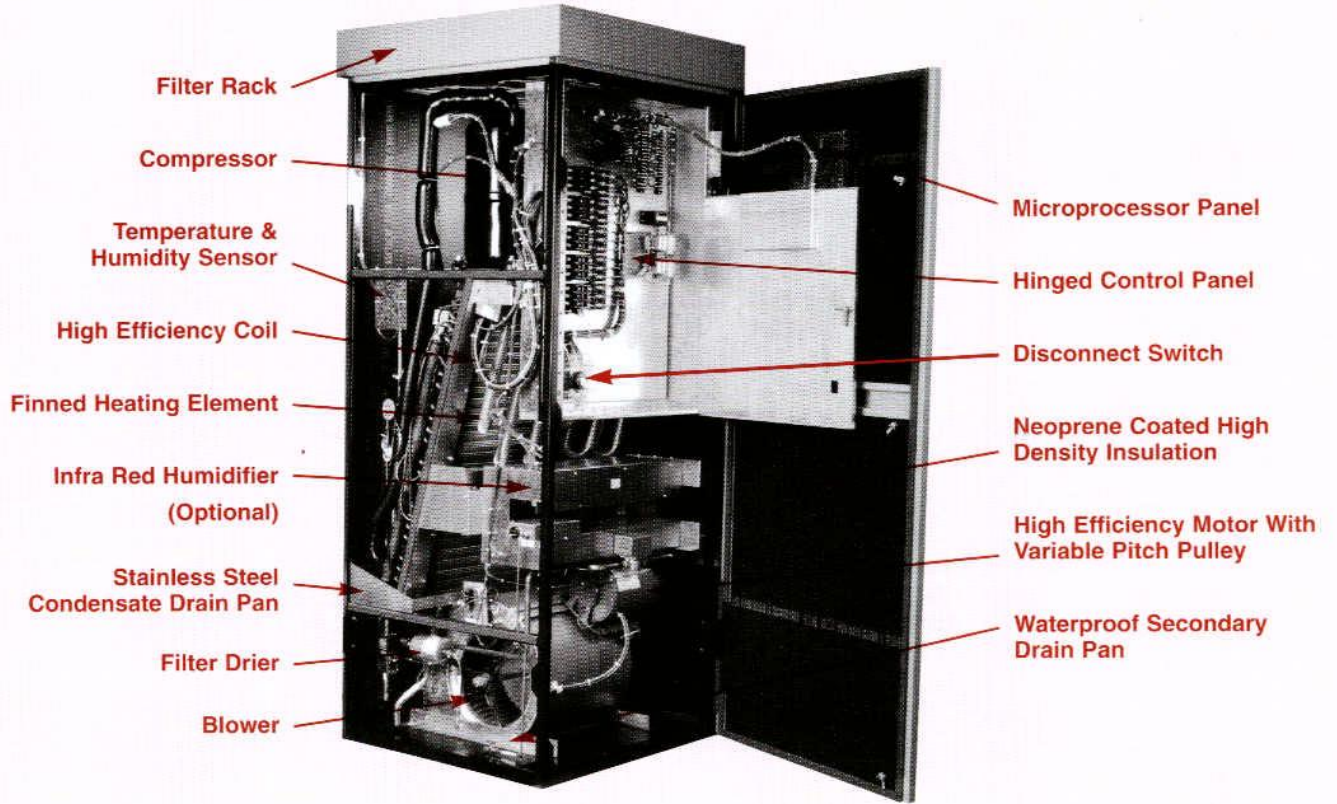

Up Flow Model

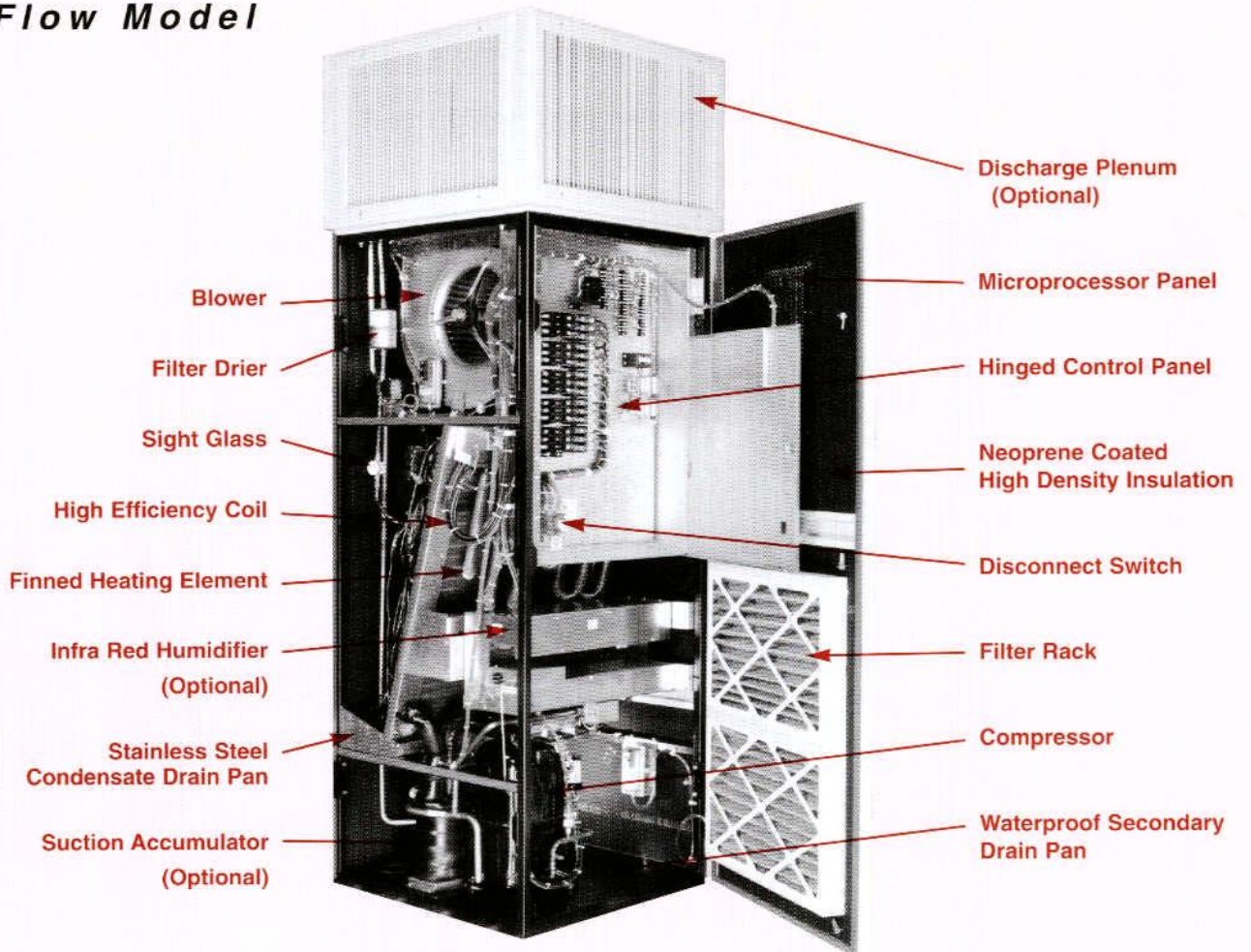

COMPU-AIRE INC. 2200 + SERIES CONTROL

Keeping the control in your hands

Compu-Aire Inc. has always focused special attention on simplicity of use, while at the same time fully exploiting the potential for flexibility and power offered by microprocessor technology.

Compu-Aire Inc. offers a diverse range of programmable controls, with state of the art user interfaces, including touch screen displays.

Compu-Aire Inc. 2200+ Series control provides a versatile approach to monitor the precise cooling and heating needs of your critical applications. With the latest technology available to the customer, we are able to provide reliable and flexible features to allow the customer to manage even the most intricate application.

Compu-Aire Inc. user friendly controllers support a variety of communications and protocols, including BacNet, LonWORKS, FTP, HTML, and Modbus.

Graphical Touch Screen Display



Included are various animated icons and non-proportional fonts in Unicode format and trend graphs. The touch screen display functions simplify setting the control parameters, allowing the customer easy access to the System 2200+ series controller.

Graphical status update with a touch of a button

 *Fan On*

 *Demand for Heat*

 *Demand for Cooling*

 *Demand for Humidification*

 *Demand for Dehumidification*

 *Excess Humidity Draining*

 *Humidifier Active*

BMS INTERFACE

Interact and monitor remotely with the pCO web card.

Compu-Aire Inc. advanced microprocessing control system provides access to our equipment through building management system (BMS) supporting industrial standard protocols including Modbus, BACnet, and LonWorks. This ensures easy access to the remote management of the unit via modem and internet.

Available Communications Options

Interfacing with the emerging protocols in the HVAC sector and based on industry standards supporting the following networks:

BACnet Over Ethernet

BACnet Over TCP/IP

BACnet MSTP

SNMP v1, v2, v3 networks with trap

Modbus

RS-485

LonWorks

BMS Communication protocols

Stand Alone Supervision Over pCO web



BMS Interface:

Our controllers are capable to receive necessary sensor inputs from BMS and utilize it to control the equipment. The controls can monitor the BMS status and if BMS became offline, controller can seamlessly switchover to local sensors and set points to maintain your data center cooling demand.

pLAN Stand alone network

Stand alone supervision over web browser

pCO Web card interface provides:

- Unit status with virtual information
- Room temperature/humidity
- Current set points for temp/humidity
- Mode of operation
- Current status for vital components such as compressors humidifiers, fan and reheat
- current active alarms
- Setpoint control for alarms

The pCO web card configuration interface provides limited access to control room temp/humidity a log with the ability to reset alarms

NOTE: Critical alarms will require manual reset at the unit level.

pLAN Stand Alone Network

Programmable Local Area Network

Local and remote monitoring can be achieved with our advanced microcontroller. Based systems are used to provide standalone supervision and control over a pLAN network giving the flexibility of a BMS system at the fraction of the cost.

The p-LAN communication option allows two or more systems to talk to each other, p-LAN can be programmed for system rotation and for system failure over redundancy.

- Supports up to 16 units
- Lead/lag with multiple active & standby
- Unit rotation and auto changeover
- Alarm switchover to standby
- Assisted cooling
- Assisted heating
- Assisted humidification
- Dehumidification

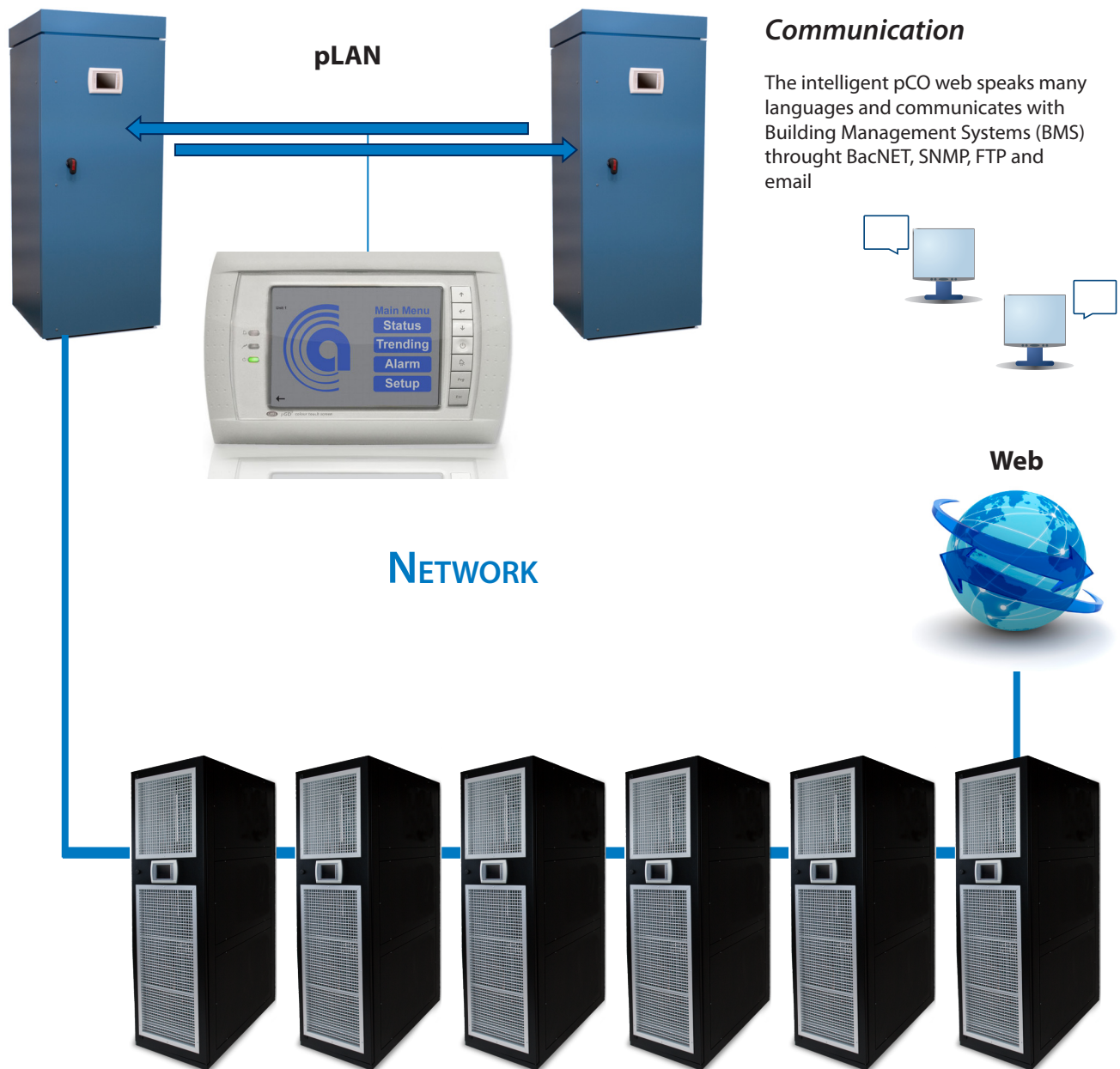

Communication

The intelligent pCO web speaks many languages and communicates with Building Management Systems (BMS) through BacNET, SNMP, FTP and email

UPFLOW SYSTEM WITH OPTIONAL PLENUM

The Compu-Kool compact and versatile designed can be configured as an Up-flow.

The unit is available for installations where raised computer floors are not required and/or not available. The unit can be provided with a duct flange for ducted supply air distribution.

Designed for in-the-space applications, where utilizing ductwork is practical. Return air entering through front grille and filters, conditioned air leaving through duct connection at top of unit or through the optional Plenum. Other configurations available.



All computers are highly sensitive to their environment. To function efficiently, they require specific temperature, humidity, and filtration conditions. Failure to meet these specified conditions can result in distorted or lost data and even complete shutdown of computer services.

Compu-Aire understands the special environmental control needs of computer, electronic and telecommunications rooms. Fully Insulated Cabinet the Compu-Aire Compu-Kool III cabinet is constructed of 14 gauge heliarc welded tubular steel for strength and protection.

Front access is made easy for servicing via well insulated access panels. A 1" thick, 1.5lb density insulation is utilized.

The cabinet has decorative front and side panels, which can be color-coordinated with the décor of the computer room.

Compu-Aire is concerned about energy conservation, which is why the Compu-Aire Compu-Kool III standard reheat is provided in two stages. Each element is finned tubular type, with a low watt density design for extended life.

Each Compu-Aire Compu-Kool III is provided with a pre-piped and pre-wired electronic electrode self-generating steam type humidifier. Completely maintenance free, the humidifier is equipped with a disposable cylinder. The vapor produced is piped directly into the supply air for efficient moisture introduction.

Easy Access To Filters the Compu-Aire Compu-Kool III has standard 2" thick pleated media high efficiency MERV 8 filters which are serviceable from the front of the unit for upflow units and from the top for downflow units.

Compu-Kool III Split System features a pre-charged evaporator coil and expansion valve in the computer room unit, with the scroll compressor, and the condensing equipment located in 4 different types of condensing units Air Cooled Condenser (ACC), Propeller fan type condensing unit (PFCU), Air Cooled Condensing Unit (ACCU), Centrifugal fan type condensing unit (CFCU), Water cooled condensing unit (WCCU) and WCCU/DFC water cooled condensing unit with remote dry fluid cooler and pump that can easily adapt to the customer needs.

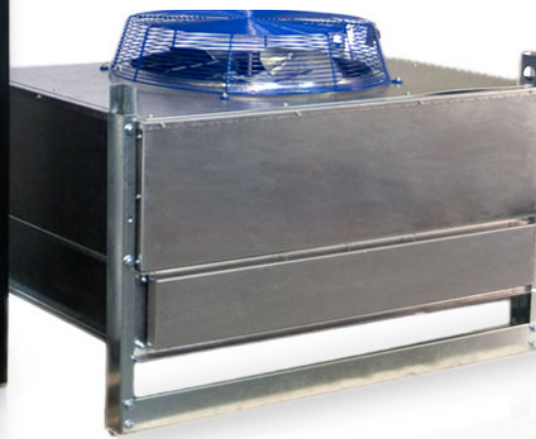

The Compu-Kool Coil is provided with high efficiency fins and a larger coil face area. The coil has been designed to provide the maximum sensible heat ratio required by computer rooms and, at the same time, minimizing energy used in air circulation. The coil is split into two stages.

VERSATIL PRECISION COOLING IN A COMPACT DESIGN

Intelligent, Adaptive and Programmable

The large color touch digital display allows you to control the Compu-Kool systems on site or remotely and is BMS friendly.

The flow of refrigerant is controlled by an externally equalized valve. The stainless steel condensate drain pan is provided under the coil with two drains.

Each Compu-Aire Compu-Kool III is equipped with high efficiency scroll compressors.

Each compressor is provided with built-in thermal overload protection, built-in pressure relief valve and built-in current overload Refrigerant Circuits a refrigerant circuit is provided with externally equalized expansion valve, sight glass with moisture indicator, filter drier, pump down cycle (air cooled units), schrader fittings, high pressure switch, low pressure switch.

Refrigeration System

Split System

This system features a precharged evaporator coil and expansion valve in the computer room unit, with the hermetic compressor, and the condensing equipment located in 4 different types of condensing units:

- Air Cooled Condenser (ACC)
- Air Cooled Condenser Unit (ACCU)
- Propeller fan type condensing unit (PFCU)
- Centrifugal fan type condensing unit (CFCU)
- Water cooled condensing unit (WCCU)
- WCCU/DFC water cooled condensing unit with remote dry fluid cooler and pump

Coil

The cooling coil is provided with high efficiency fins and a larger coil face area. The coil has been designed to provide the maximum sensible heat ratio required by computer rooms and, at the same time, minimizing energy used in air circulation. The coil is split into two stages. The flow of refrigerant is controlled by an externally equalized valve.



Condensate Drain Pan

The stainless steel condensate drain pan is provided under the coil with two drains.

Compressor

Each Compu-Aire Compu-Kool III is equipped with high efficiency scroll compressors. Each compressor is provided with:

- Built-in thermal overload protection
- Built-in pressure relief valve
- Built-in current overload



Refrigerant Circuits

A refrigerant circuit is provided with:

- Externally equalized expansion valve
- Sight glass with moisture indicator
- Filter drier
- Pump down cycle (air cooled units)
- Schrader fittings
- High pressure switch
- Low pressure switch

R-407C
Refrigerant

Fully Insulated Cabinet

The Compu-Aire Compu-Kool III cabinet is constructed of 14 gauge heliarc welded tubular steel for strength and protection. Front access is made easy for servicing via well insulated access panels. A 1" thick, 1.5lb density insulation is utilized. The cabinet has decorative front and side panels, which can be color-coordinated with the décor of the computer room.



Maintenance Free Humidifier

Each Compu-Aire Compu-Kool III is provided with a pre-piped and pre-wired electronic electrode self generating steam type humidifier. Completely maintenance free, the humidifier is equipped with a disposable cylinder. The vapor produced is piped directly into the supply air for efficient moisture introduction.



Dehumidification Cycle

High humidity can cause moisture to accumulate on paper media, resulting in handling problems. When the Compu-Aire Compu-Kool III is switched to the dehumidification mode, the reheat feature provided has sufficient capacity to maintain computer room dry bulb conditions.



Easy Access To Filters

The Compu-Aire Compu-Kool III has standard 2" MERV 8 thick pleated media high efficiency filters which are serviceable from the front of the unit for upflow units and from the top for downflow units.

high voltage control panel

Each Compu-Aire Compu-Kool III is equipped with a high voltage panel containing the following components:

- Disconnect switch
- Contactors
- Relays
- Fuse blocks
- Fuses
- Transformer
- Branch circuit protection for all components
- Terminal blocks

Non-Locking Type Disconnect Switch:

(optional) Mounted on the high voltage section of the electrical panel, access to the high voltage panel is permitted after the switch is in the ON or OFF position.

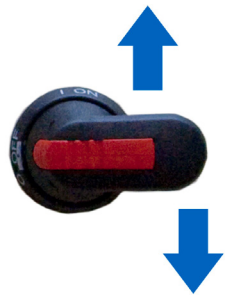

Low Noise Level Fan

The fan section features:

- Permanently lubricated ball bearings
- Variable pitch drive set
- Draw through air-flow for even air distribution

Low Ambient Control

Low ambient control system features a variable speed motor specially designed to be used in conjunction with a solid state speed controller. The speed controller senses the head pressure of the compressor and varies the speed of the fan to maintain constant condensing temperature. This low ambient control allows system operation in temperatures as low as -20°F ambient temperature.

TECHNICAL DATA
**SELF CONTAINED AIR COOLED SYSTEM CKA
WITH AIR COOLED CONDENSER**
TABLE NO.1

NOMINAL TONS MODEL	2 CKA-2	3 CKA-3	4 CKA-4	5 CKA-5
ENERGY EFFICIENCY RATIO	9.7	10.6	9.2	10.2
CAPACITY DATA				
80°F DB, 67°F WB (26.7°C DB, 19.4°C WB) 50% RH ENTERING AIR				
Total-BTU/HR(kW)	33973(9.9)	43750(12.8)	59600(17.4)	64600(18.9)
Sensible-BTU/HR(kW)	23713(6.7)	34350(10.1)	50335(14.7)	54200(15.9)
75°F DB, 62.5°F WB (23.9°C DB, 16.9°C WB) 50% RH ENTERING AIR				
Total-BTU/HR(kW)	26501(7.8)	41550(12.2)	53715(15.7)	62100(18.2)
Sensible-BTU/HR(kW)	21443(6.3)	33500(9.8)	48219(14.1)	52120(15.3)
72°F DB, 60°F WB (22.2°C DB, 15.5°C WB) 50% RH ENTERING AIR				
Total-BTU/HR(kW)	23415(6.8)	39820(11.7)	44348(13.0)	60950(17.9)
Sensible-BTU/HR(kW)	20216(5.9)	32320(9.5)	44348(13.0)	52120(15.3)
72°F DB, 58.6°F WB (22.2°C DB, 14.8°C WB) 45% RH ENTERING AIR				
Total-BTU/HR(kW)	20349(5.9)	38320(11.2)	44348(13.0)	59150(17.3)
Sensible-BTU/HR(kW)	20349(5.9)	35120(10.3)	44348(13.0)	59150(17.3)
FAN DATA-Double width double inlet belt driven - Variable pitch pulley				
Fan Motor HP	3/4	3/4	1	1 1/2
CFM (L/s)	1000 (470)	1800 (850)	2350 (1104)	3050 (1439)
ESP IN. WC(Pa)	0.3 (75)	0.3 (75)	0.3 (75)	0.3 (75)
COIL DATA- High efficiency copper tubing-aluminum fins				
Face Area FT ² (m ²)	5.9(0.55)	5.9(0.55)	5.9(0.55)	5.9(0.55)
Rows	2	2	3	4
COMPRESSOR DATA- Heat pump duty scroll				
Size	2	3	4	5
EER	13.8	13.7	13.8	14.0
REHEAT DATA- Electric- 2 stages				
kW	6	6	10	10
BTU/HR - Includes Fan Motor	22510	22510	40650	40650
HUMIDIFIER DATA-Electronic self generating steam type with disposable cylinder				
kW	3.4	3.4	3.4	3.4
LBS/HR (kg/hr)	10.0(4.5)	10.0(4.5)	10.0(4.5)	10.0(4.5)
FILTER DATA-30% Efficiency based on ASHRAE 52-76 standard				
Downflow 14 X 25 X 2	2	2	2	2
Upflow 16 X 25 X 2	2	2	2	2
Effective Area FT ² (m ²)	20.2(1.88)	20.2(1.88)	20.2(1.88)	20.2(1.88)
PIPING CONNECTION DATA - All sizes in copper OD				
Liquid Line	1/2"	1/2"	5/8"	5/8"
Hot Gas Line	5/8"	5/8"	7/8"	7/8"
Humidifier Water Supply	1/4"	1/4"	1/4"	1/4"
Condensate Drain	3/4"	3/4"	3/4"	3/4"
WEIGHT LBS(kg)	450(204)	550(250)	600(272)	650(295)
AIR COOLED CONDENSER BASED ON 95°F (35°C) AMBIENT-Variable Fan Speed Type - Good down to -20°F (-7°C).				
CONDENSER MODEL	ACC-2	ACC-5	ACC-5	ACC-6
FAN DATA - DIRECT DRIVE - Propeller Fan Type				
CFM (L/s)	2500(1180)	5200(2454)	5200(2454)	5100(2407)
Motor HP	1/6	3/4	3/4	3/4
Fan Size	18	24	24	24
PIPING CONNECTION DATA - All sizes in copper OD				
Liquid Line	1/2"	7/8"	7/8"	7/8"
Hot Gas Line	5/8"	1 1/8"	1 1/8"	1 1/8"
WEIGHT LBS(kg)	240(109)	275(125)	310(140)	350(159)

BOLD FACE DATA IN METRIC UNITS

DIMENSIONAL DATA

DOWNFLOW UNIT

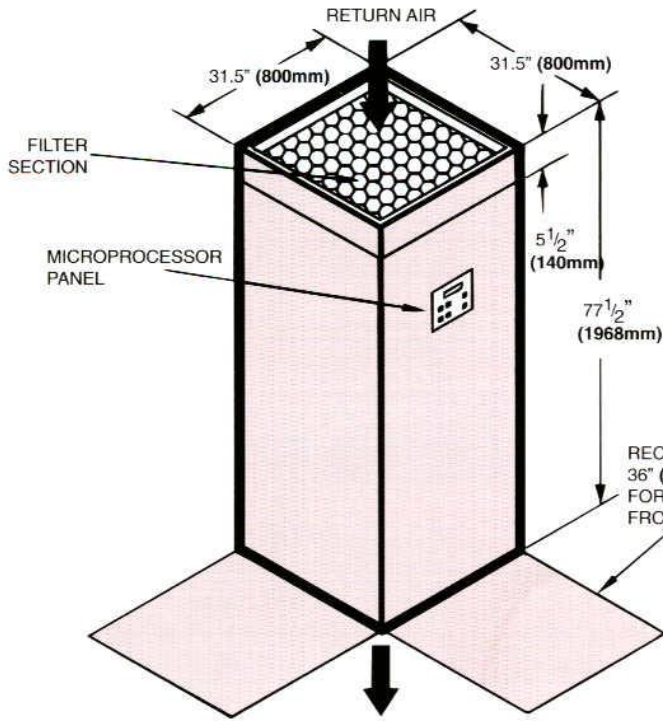

UPFLOW UNIT

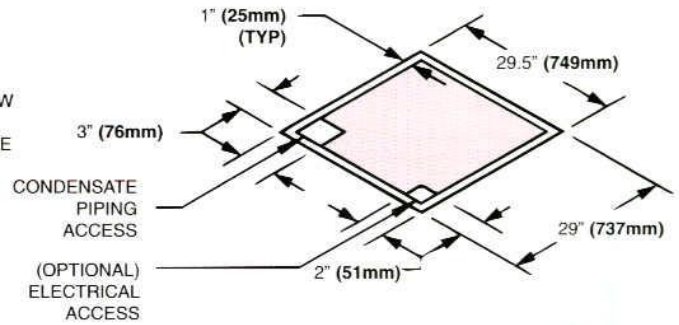
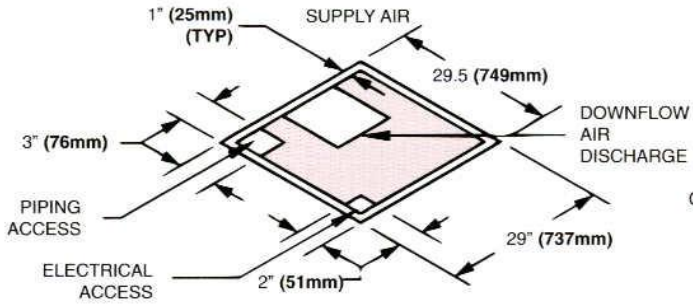
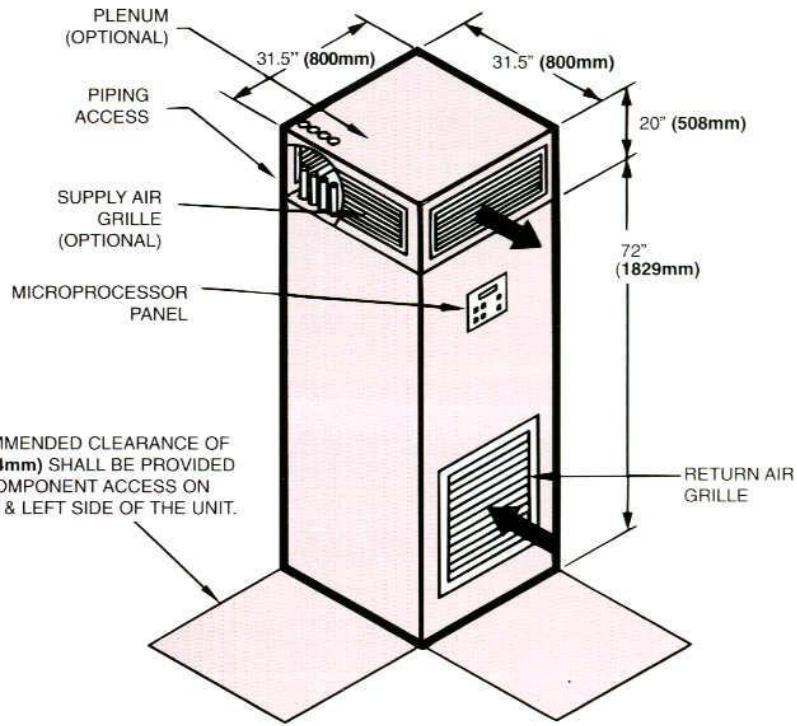

FLOOR CUTOUT DETAIL

FLOOR CUTOUT DETAIL

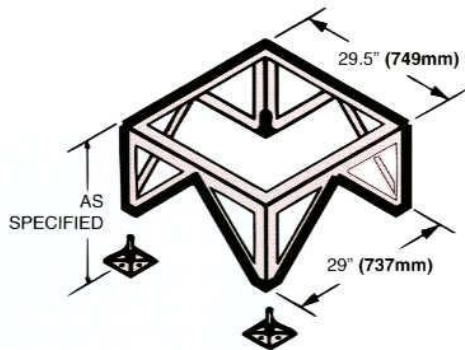

(OPTIONAL) FLOOR STAND DETAIL

BOLD FACE DATA IN METRIC UNITS

DIMENSIONAL DATA

AIR COOLED CONDENSER, DRY FLUID COOLER, AND PUMP PACKAGE

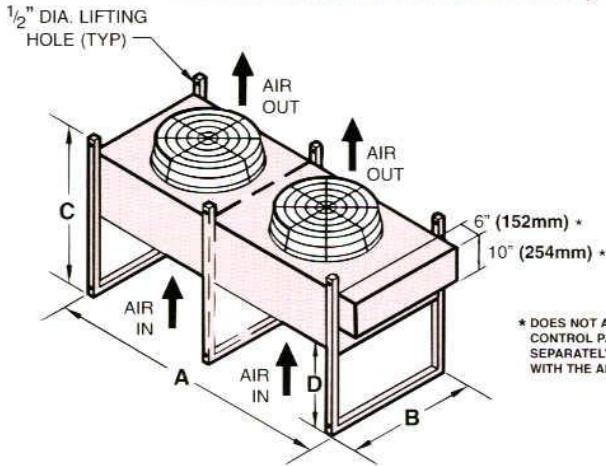

DIMENSIONS FOR AIR COOLED CONDENSERS AND DRY FLUID COOLERS

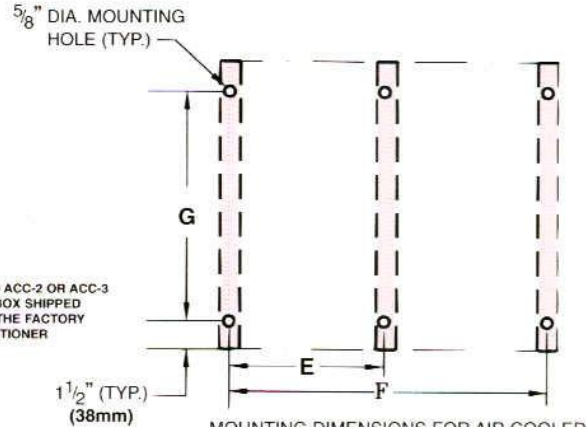

MOUNTING DIMENSIONS FOR AIR COOLED CONDENSERS AND DRY FLUID COOLERS

* DOES NOT APPLY TO ACC-2 OR ACC-3 CONTROL PANEL & BOX SHIPPED SEPARATELY FROM THE FACTORY WITH THE AIR CONDITIONER

DIMENSIONAL DATA		TABLE NO. 10								
CKIII	AIR COOLED CONDENSER	A	B	C	D	E	F	G	# OF FANS	WEIGHT lbs (kg)
2 TON	ACC-2	25 (635)	26.25 (667)	22 (559)	6 (152)	23.2 (587)	—	25.5 (648)	1	110 (50)
3 TON	ACC-5	32.25 (819)	48 (1219)	42.75 (1086)	18.25 (467)	30 (762)	—	45 (1143)	1	220 (100)
4 TON	ACC-5	32.25 (819)	48 (1219)	42.75 (1086)	18.25 (467)	30 (762)	—	45 (1143)	1	220 (100)
5 TON	ACC-6	32.25 (819)	48 (1219)	42.75 (1086)	18.25 (467)	30 (762)	—	45 (1143)	1	220 (100)

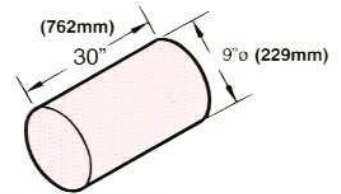

7.5 GAL EXPANSION TANK (OPTIONAL)

DIMENSIONAL DATA		TABLE NO. 11								
CKIII	DRY FLUID COOLER	A	B	C	D	E	F	G	# OF FANS	WEIGHT lbs (kg)
2 TON	DFC-3	25 (635)	26.25 (667)	22 (559)	6 (152)	23.2 (587)	—	25.5 (648)	1	145 (66)
3 TON	DFC-6	32.25 (819)	48 (1219)	42.75 (1086)	18.25 (467)	30 (762)	—	45 (1143)	1	245 (111)
4 TON	DFC-8	32.25 (819)	48 (1219)	42.75 (1086)	18.25 (467)	30 (762)	—	45 (1143)	1	295 (134)
5 TON	DFC-11	62.25 (1581)	48 (1219)	42.75 (1086)	18.25 (467)	30 (762)	60 (1524)	45 (1143)	2	340 (155)

DUAL CIRCUITS

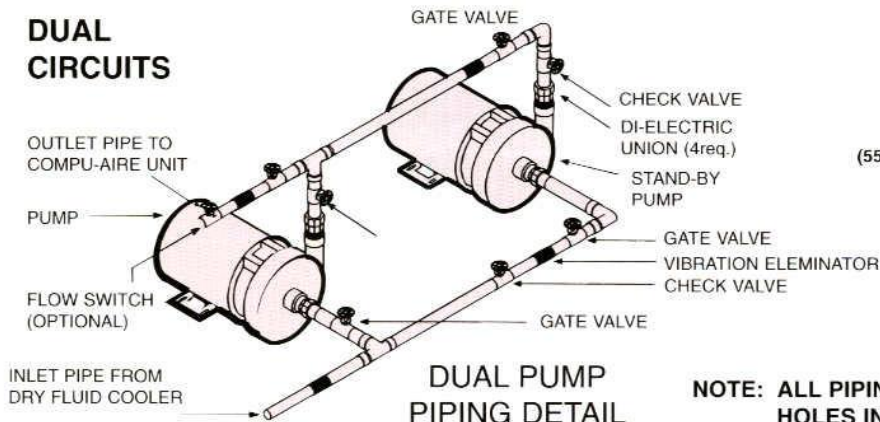

DUAL PUMP PIPING DETAIL

NOTE: ALL PIPING, FITTINGS & VALVES ARE FIELD PROVIDED HOLES IN ENCLOSURE ARE DONE IN THE FIELD

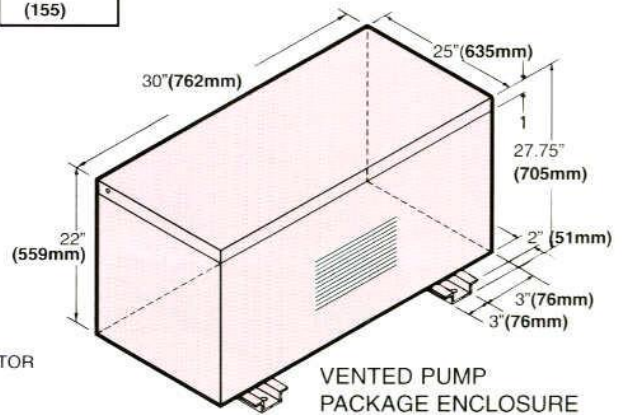

VENTED PUMP PACKAGE ENCLOSURE

BOLD FACE DATA IN METRIC UNITS

DIMENSIONAL DATA FOR CONDENSING UNITS

2 & 3 TON

4 & 5 TON

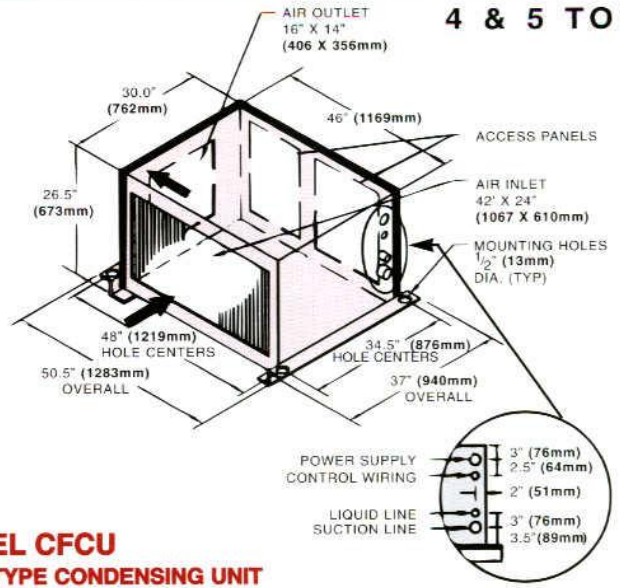
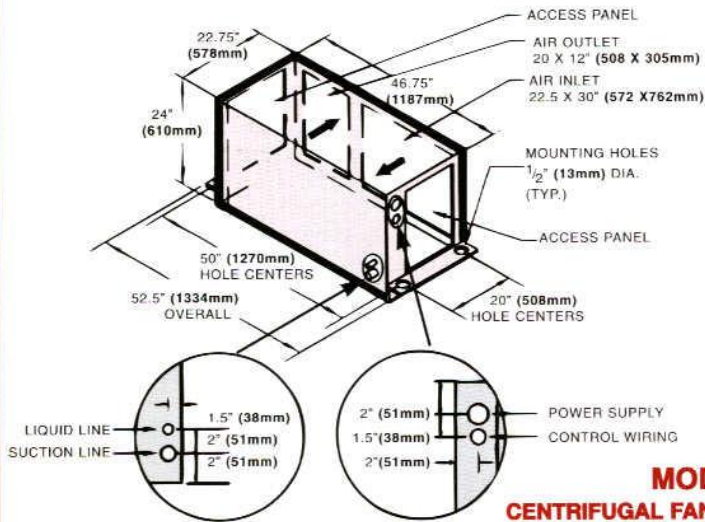

**MODEL CFCU
CENTRIFUGAL FAN TYPE CONDENSING UNIT**

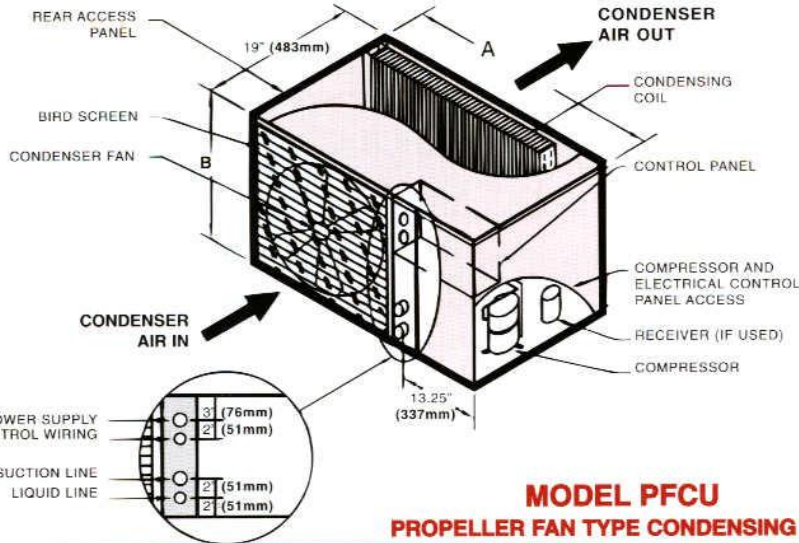
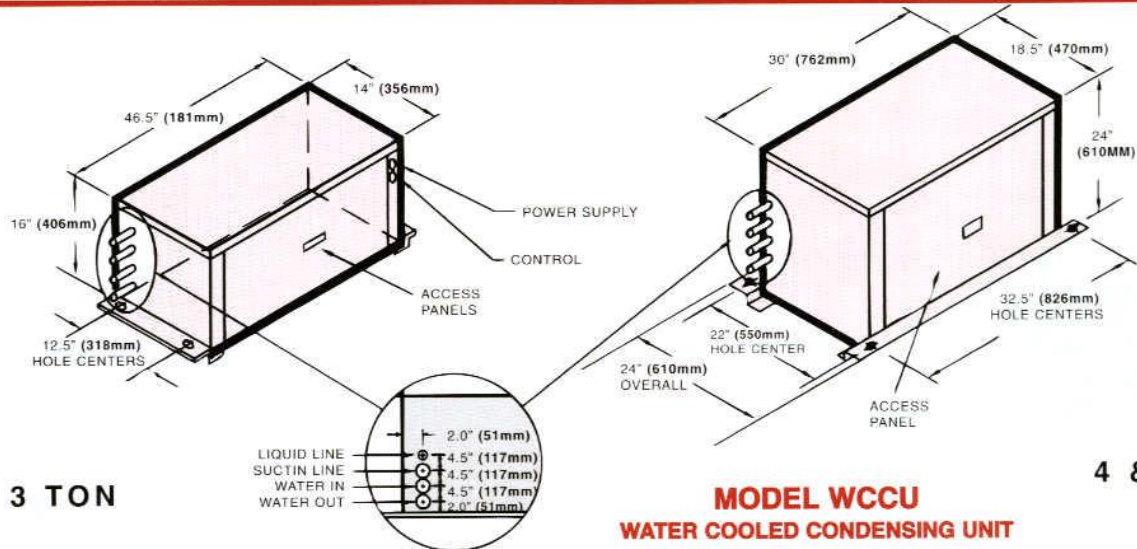

TABLE NO. 12

PFCU MODEL	NOMINAL TONNAGE	A in. (mm)	B in. (mm)	WEIGHT lbs (kg)
02	2	40" (1016)	23" (584)	300 (136)
03	3	48" (1219)	31" (787)	325 (147)
04	4	54" (1372)	37" (940)	340 (154)
05	5	54" (1372)	37" (940)	340 (154)

**MODEL PFCU
PROPELLER FAN TYPE CONDENSING UNIT**



2 & 3 TON

4 & 5 TON

**MODEL WCCU
WATER COOLED CONDENSING UNIT**

BOLD FACE DATA IN METRIC UNITS

ELECTRICAL DATA

Compu Kool III Air Conditioners using scroll compressor, electric reheat and electronic electrode type humidifier. For electrical data using alternate reheat, no reheat, alternate humidifier, or no humidifier, consult factory.

TABLE NO.13

VOLT/PH/HZ	AIR COOLED - CKA		WATER COOLED - CKW	
	CKA-23*	CKA-33*	CKW-33*	CKW-43*
	CKG-23*	CKG-33*	CKG-33*	CKG-43*
	CKG-23* EM	CKG-33* EM	CKG-43* EM	CKG-53* EM
208/3/60				
FLA	30.2	31.1	46.7	52.8
MCA	37.0	38.1	57.4	64.6
MFS	50A	50A	70A	80A
380/3/50				
FLA	14.5	16.0	25.0	27.3
MCA	17.8	19.7	30.9	33.6
MFS	20A	25A	40A	45A
460/3/60				
FLA	13.5	14.7	22.6	25.0
MCA	16.5	18.0	27.8	33.6
MFS	20A	25A	35A	40A
575/3/60				
FLA	11.3	11.7	17.8	19.9
MCA	13.8	14.4	21.9	24.4
MFS	20A	20A	30A	30A

TABLE NO.14

VOLT/PH/HZ	EVAPORATOR SECTION - CKE AND CHILLED WATER - CKC			
	CKE-23*	CKE-33*	CKE-43*	CKE-53*
	CKC-23*	CKC-33*	CKC-43*	CKC-53*
208/3/60				
FLA	19.9	19.8	31.7	33.5
MCA	24.8	24.8	39.7	41.9
MFS	25A	25A	40A	45A
380/3/50				
FLA	10.3	10.3	16.8	17.3
MCA	12.9	12.9	21.0	21.6
MFS	15A	15A	25A	25A
460/3/60				
FLA	8.9	8.9	14.4	15.0
MCA	11.2	11.2	17.9	18.8
MFS	15A	15A	20A	20A
575/3/60				
FLA	7.0	7.0	11.4	12.0
MCA	8.8	8.8	14.3	15.0
MFS	15A	15A	20A	20A

TABLE NO.15

VOLT/PH/HZ	CENTRIFUGAL FAN CONDENSING UNIT - CFCU			
	CFCU-23*	CFCU-33*	CFCU-43*	CFCU-53*
208/3/60				
FLA	15.5	16.4	20.0	24.3
MCA	18.1	19.3	23.8	29.1
MFS	30A	30A	40A	50A
380/3/50				
FLA	7.4	7.4	10.3	12.1
MCA	8.6	8.8	12.4	14.6
MFS	15A	15A	20A	25A
460/3/60				
FLA	6.9	8.2	10.6	12.4
MCA	8.0	9.6	12.7	14.9
MFS	15A	15A	20A	25A
575/3/60				
FLA	5.3	5.7	8.4	9.9
MCA	6.4	6.9	10.0	11.9
MFS	15A	15A	15A	20A

TABLE NO.16

VOLT/PH/HZ	PROPELLER FAN CONDENSING UNIT - PFCU			
	PFCU-23*	PFCU-33*	PFCU-43*	PFCU-53*
208/3/60				
FLA	12.9	13.8	20.0	24.3
MCA	15.5	16.7	23.8	29.1
MFS	25A	30A	40A	50A
380/3/50				
FLA	7.2	7.0	10.7	12.5
MCA	8.4	8.4	12.8	15.0
MFS	15A	15A	20A	25A
460/3/60				
FLA	6.6	6.9	10.7	12.5
MCA	7.75	8.3	12.8	15.0
MFS	15A	15A	20A	25A
575/3/60				
FLA	6.0	6.0	8.0	10.5
MCA	7.2	7.2	9.4	12.5
MFS	15A	15A	15A	20A

TABLE NO.17

VOLT/PH/HZ	WATER COOLED CONDENSING UNIT - WCCU			
	WCCU-23*	WCCU-33*	WCCU-43*	WCCU-53*
208/3/60				
FLA	10.5	11.4	15.0	19.3
MCA	13.1	14.3	18.8	24.1
MFS	25A	25A	35A	45A
380/3/50				
FLA	4.6	5.7	8.2	10.0
MCA	5.7	7.1	10.3	12.5
MFS	15A	15A	20A	25A
460/3/60				
FLA	4.3	5.7	8.6	10.0
MCA	5.4	7.1	10.3	12.5
MFS	15A	15A	20A	25A
575/3/60				
FLA	4.3	4.7	6.4	7.9
MCA	5.4	5.9	8.0	9.9
MFS	15A	15A	15A	20A

ELECTRICAL DATA

AIRCOOLED CONDENSER (ACC)										TABLE NO.18					
VOLTAGE/ PHASE/ HERTZ															
MODEL	208V/1/60			208-230V/3/60			380V/3/50			460V/3/60			575V/3/60		
	FLA	MCA	MFS	FLA	MCA	MFS	FLA	MCA	MFS	FLA	MCA	MFS	FLA	MCA	MFS
ACC-2	2.9	3.6	15	N/A	N/A	N/A	N/A	N/A	N/A	N/A	N/A	N/A	N/A	N/A	N/A
ACC-5	4.5	5.6	15	4.5	5.6	15	2.3	2.9	15	2.3	2.9	15	2.3	2.9	15
ACC-5	4.5	5.6	15	4.5	5.6	15	2.3	2.9	15	2.3	2.9	15	2.3	2.9	15
ACC-6	4.5	5.6	15	4.5	5.6	15	2.3	2.9	15	2.3	2.9	15	2.3	2.9	15

DRY FLUID COOLER (DFC)										TABLE NO.19						
VOLTAGE/ PHASE/ HERTZ																
MODEL	PUMP HP	208V/1/60			208-230V/3/60			380V/3/50			460V/3/60			575V/3/60		
		FLA	MCA	MFS	FLA	MCA	MFS	FLA	MCA	MFS	FLA	MCA	MFS	FLA	MCA	MFS
DFC-3	0.75	9.8	11.5	15	N/A	N/A	N/A	N/A	N/A	N/A	N/A	N/A	N/A	N/A	N/A	
DFC-6	0.75	10.9	13.1	15	7.3	8.4	15	3.7	4.3	15	3.7	4.3	15	3.7	4.3	
DFC-8	1.0	12.5	14.5	20	8.1	9.2	15	4.1	4.7	15	4.1	4.7	15	4.1	4.7	
DFC-11	1.0	17.0	19.0	25	12.6	13.7	15	6.4	7.0	15	6.4	7.0	15	6.4	7.0	

FAN MOTOR AND PUMP MOTOR ELECTRICAL DATA										TABLE NO.20		
VOLTAGE/ PHASE/ HERTZ												
HORSEPOWER	208V/3/60		230V/3/60		380V/3/50		460V/3/60		575V/3/60			
	FLA	LRA	FLA	LRA	FLA	LRA	FLA	LRA	FLA	LRA		
0.75	3.0	18.5	2.9	16.8	1.2	8.4	1.5	8.4	1.0	6.6		
1.0	3.9	23.1	3.6	21.0	1.6	10.8	1.8	10.8	1.4	8.4		
1.5	5.7	33.0	5.2	30.0	2.1	15.0	2.4	15.0	2.0	12.6		

HERMETIC COMPRESSORS					TABLE NO.21		
VOLTAGE/ PHASE/ HERTZ							
SIZE-TONS	208-230V/3/60		460V/3/60		575V/3/60		
	RLA	LRA	RLA	LRA	RLA	LRA	
2	8.5	65.0	4.5	27.0	N/A	N/A	
3	14.3	74.0	6.7	41.0	N/A	N/A	
4	17.9	90.0	8.6	45.0	6.0	30.0	
5	21.4	130.0	9.6	65.0	7.9	52.0	

SCROLL COMPRESSORS					TABLE NO.22		
VOLTAGE/ PHASE/ HERTZ							
SIZE-TONS	208-230V/3/60		460V/3/60		575V/3/60		
	RLA	LRA	RLA	LRA	RLA	LRA	
2	8.6	55.0	4.3	27.0	4.3	23.0	
3	11.4	77.0	5.7	39.0	4.7	30.6	
4	15.0	99.0	8.2	49.5	6.4	40.0	
5	19.3	137.0	10.0	62.0	7.9	50.0	

REHEAT						TABLE NO.23
VOLTAGE/ PHASE/ HERTZ						
kW.	208V/3/60	230V/3/60	380V/3/50	460V/3/60	575V/3/60	
6.0	16.7	15.1	9.1	7.5	6.0	
10.0	27.8	25.1	15.2	12.6	10.0	

HUMIDIFIER							TABLE NO.24
VOLTAGE/ PHASE/ HERTZ							
TYPE	kW.	208V/3/60	230V/3/60	380V/3/50	460V/3/60	575V/3/60	
INFRARED	4.8	13.3	12.1	7.3	6.0	N/A	
NORTEC	3.4	16.3	14.8	9.8	7.7	6.2	

NOTES:

1. **LRA**=Locked Rotor Amps, **RLA**=Rated Load Amps, **FLA**=Full Load Amp., **MCA**=Minimum Circuit Ampacity, **MFS**=Maximum recommended fuse size
2. Full load amps and minimum circuit ampacity is not the total sum of full load amps of all the components. It is the sum of components operating in the dehumidification mode. Humidifier and Reheat do not operate simultaneously.
3. All applicable portions of, NATIONAL, STATE, LOCAL, electrical codes, OSHA standards, and FIRE MARSHALL requirements must be consulted and complied with prior to installation of this equipment.
4. **N/A**: Not Applicable



While every precaution has been taken to ensure accuracy and completeness in this brochure Compu-Aire Inc. assumes no responsibility for damages resulting from use of this information or for any error or omissions. Subject to change without notice.